

TUTTI I PROFILI SONO REALIZZATI IN ALLUMINIO VERNICIATO A POLVERI POLIESTERE LEGA 6060 STATO T5 o T6 CON UNO SPESSORE VARIABILE TRA 1,5 - 2 mm. (scala 1:2)

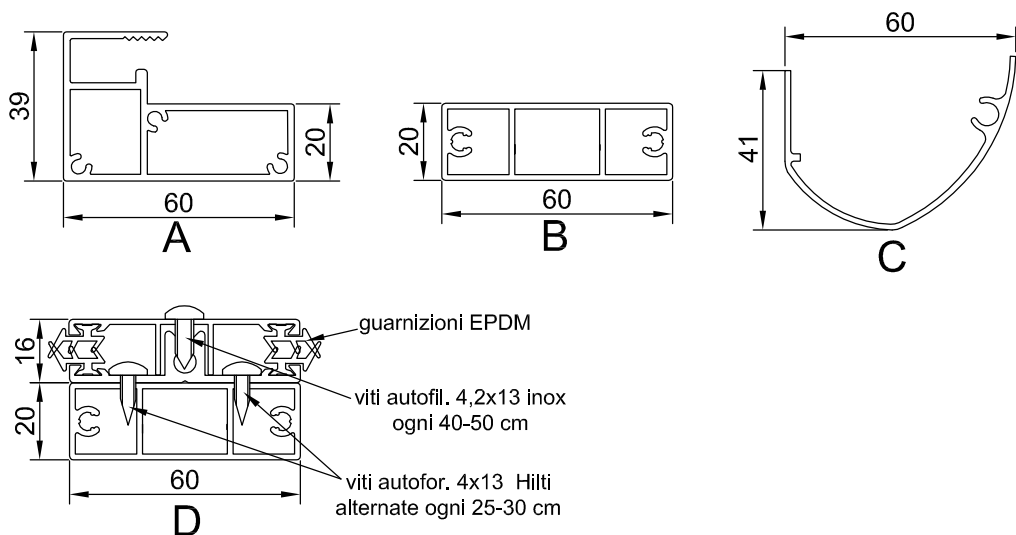

TESTATO DA

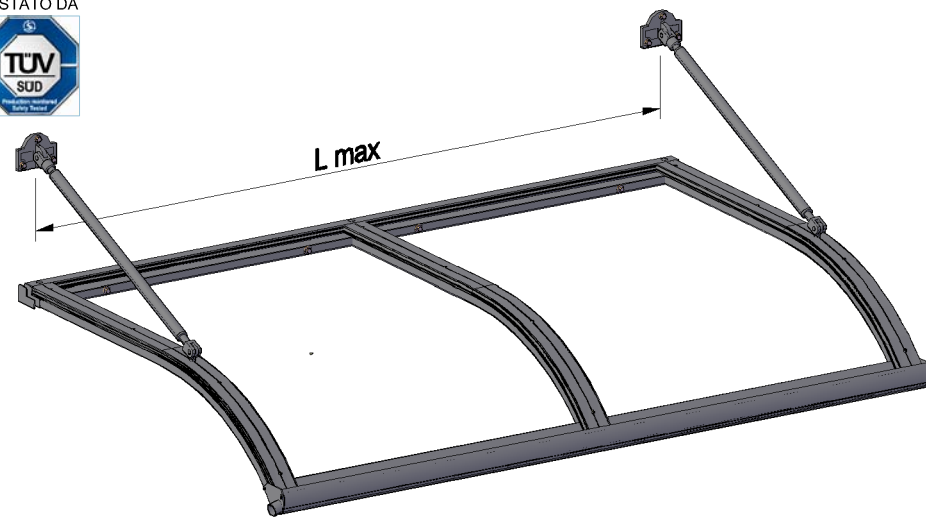

CODICE	S cm	L max cm	Area mq	H cm	h cm
TR060	60	280	1,68	23,6	24
TR070	70	270	1,89	26,4	24
TR080	80	260	2,08	29,2	30
TR090	90	250	2,25	32	33
TR100	100	240	2,4	34,8	37
TR110	110	218	2,39	37,6	40
TR120	120	200	2,4	40,4	43
TR130	130	184	2,39	43,2	46
TR140	140	170	2,38	46	49
TR150	150	160	2,4	48,8	52

CODICE TRxxx	DATA 24/04/12	PROFILI ALLUMINIO ESTRUSO ALLUMINIO 6060 STATO T5 o T6
	SCALA ---	LASTRE DI COPERTURA POLICARBONATO COMPATTO SPESS. 4 mm.

DESCRIZIONE PENSILINA ONDA S = 60-150	GUARNIZIONI EPDM
--	---------------------

DISEGNATO	APPROVATO
-----------	-----------

REV.	DESCRIZIONE REVISIONE	DATA
06	----	----
05	----	----
04	----	----
03	----	----
02	----	----
01	----	----
00	PRIMA EMISSIONE DEL DISEGNO	24/04/12

