

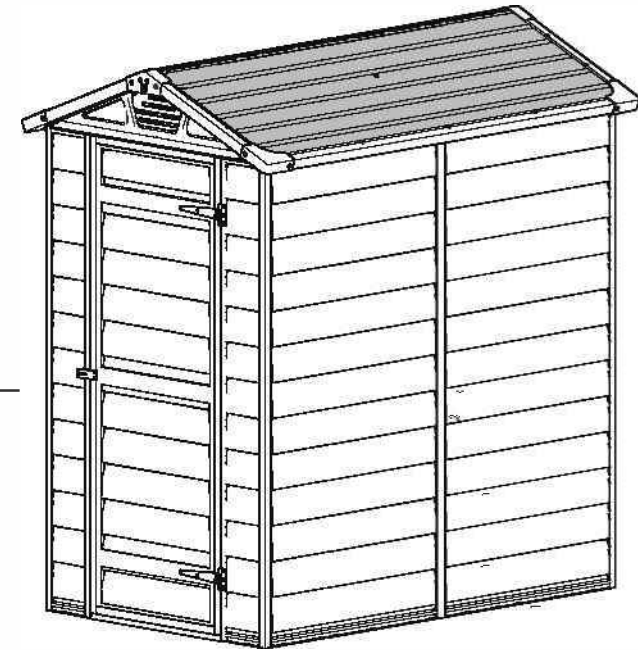

VIA SCHIAVONIA 76 - 31022 PREGANZIOL (TV)
0422 - 331577 - WWW.TECHIN.IT - INFO@TECHIN.IT



Assembly Instructions

Skylight Shed™ - 4x6

Approx. Dim.

186L x 123W x 200H cm / 73.2"L x 48.4"W x 78.7"H

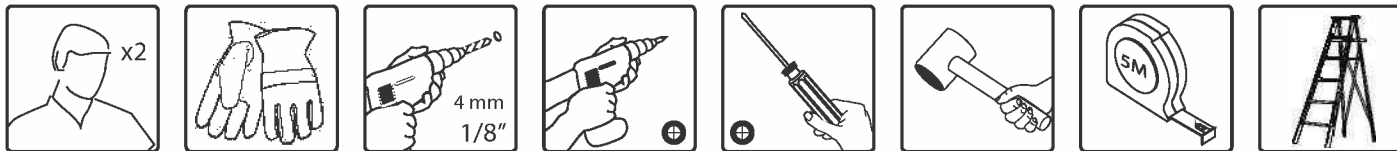

After Sale Service

Email: customer.service@palram.com

USA 877-627-8476
Canada 1 800-866-5749

England 01302-380775
Germany 0180-522-8778

France 0169-791-094
International +972 4-848-6942

www.palramapplications.com

IMPORTANT

Please read these instructions carefully before you start to assemble this shed.
Please carry out the steps in the order set out in these instructions.
Keep these instructions in a safe place for future reference.

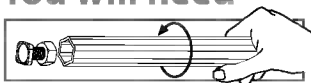
You will need

T001 - (supplied)



(these items not supplied)

Safety

- This shed must be placed and fixed on a leveled surface to ensure its stability. Make sure that screws and anchors are compatible with surface type.
- Some parts have metal edges. Please be careful when handling components.
- Always wear gloves, eye protection, and long sleeves when assembling or performing any maintenance on your shed.
- Do not attempt assemble on days with strong winds or low temperatures. If using a stepladder or power tools ensure that you follow the manufacturer's safety advice.
- Do not stand on the roof.
- Do not store hot items such as recently used grills, blowtorches etc. in the shed.
- Heavy or sharp articles should not be leaned against the wall panels.
- To prevent suffocation, do not allow children to play with packing materials.
- Shed must be secured by drilling through floor panels holes locations and inserting suitable screws into ground

Before you start

- Consult your local authorities for any building limitations or permits required to construct this garden shed.
- Complete site preparation before unpacking parts and beginning assembly.
- It is highly recommended to be assisted by a second person in some steps.
- Sort the parts and check against the contents parts list.
- Please take safety precautions during assembly.

During Assembly

When encountering the information icon, please refer to the relevant assembly step for additional comments and assistance.



This icon indicates that the installer should be inside the product.



This icon indicates that the installer should be outside the product.

**Attention:**

- It is important to drill the screws at the top of the panel ridge and to make sure that screws penetrate through the panel in order to have maximum durability.
- Make sure to position the panel's bottom ridge towards the shed floor and that it is enclosing it.

Step 2: Place the back wall panel on the shed base panel according to the stamped serial number (**part 7700**).

Step 18:

1. Before connecting the screw, please slide the profile all the way through the meeting point with the internal brake
2. Please note that the holes in **part 7402** must face downcast, as well as the rounded side should be facing up.

Step 29: Note that panel and profiles connected in the right direction as well as the profiles holes placed correctly as illustrated.

Step 38: Anchor the shed on a solid surface and use suitable screws and plugs according to the ground.

*company does not supply plugs and screws for anchoring stage.

Do not tighten screws and nuts (411 & 412) until completion of assembly process. These 2 icons indicate if screws' tightening is required or not.



412



411



WICHTIG

Bitte lesen Sie die vorliegenden Anweisungen sorgfältig durch, bevor Sie mit dem Zusammenbau dieses Schuppens beginnen. Bitte führen Sie die Schritte in der in der vorliegenden Anleitung aufgeführten Reihenfolge aus. Bewahren Sie die Anleitung für eine spätere Bezugnahme an einem sicheren Ort auf.

Sie werden brauchen

T001 - (Werkzeuge)



(Diese Artikel werden nicht mitgeliefert)

Sicherheit

- Dieser Schuppen muss auf einer ebenen Oberfläche aufgestellt und verankert werden, um seine Stabilität zu gewährleisten. Bitte vergewissern Sie sich, dass die Schrauben und Verankerungen der Art des Bodens entsprechen.
- Einige Teile haben Metallkanten. Bitte lassen Sie bei der Handhabung der Bauteile Vorsicht walten.
- Tragen Sie immer Handschuhe, Augenschutz und lange Ärmel, wenn Sie Ihren Schuppen zusammenbauen oder an ihm Instandhaltungsarbeiten durchführen.
- Versuchen Sie nicht, den Schuppen an Tagen mit starkem Wind oder niedrigen Temperaturen zu montieren. Wenn Sie eine Stehleiter oder elektrische Werkzeuge einsetzen, stellen Sie bitte sicher, dass Sie den Sicherheitshinweisen des Herstellers folgen.
- Stehen Sie nicht auf dem Dach.
- Lagern Sie keine heißen Gegenstände, wie zum Beispiel etwa vor kurzem benutzte Grillgeräte, Schneidbrenner, etc. in dem Schuppen.
- Schwere oder scharfkantige Gegenstände sollten nicht gegen die Wandpaneel gelehnt werden.
- Um Erstickungsunfälle zu vermeiden, gestatten Sie Kindern nicht, mit dem Verpackungsmaterial zu spielen.
- Shed muss durch Bohren durch Bodenplatten Löcher Standorte und geeigneten Schrauben in den Boden gesichert werden

Ziehen Sie die Schrauben und Muttern (411 & 412) nicht fest, bevor Sie den Montagevorgang abgeschlossen haben. Diese beiden Symbole zeigen an, ob ein Festziehen der Schrauben erforderlich ist oder nicht.

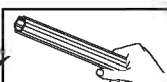

412



411

**Bevor Sie beginnen**

- Consult Fragen Sie bei den örtlichen Behörden nach, ob es irgendwelche Einschränkungen für den Aufbau gibt oder Genehmigungen erforderlich sind, um diesen Gartenschuppen aufzustellen.
- Der Schuppen muss auf einer ebenen Fläche aufgestellt und verankert werden.
- Schließen Sie die Vorbereitung des Standortes ab, bevor Sie die Bauteile auspacken und mit dem Zusammenbau beginnen.
- Es wird dringend empfohlen, bei einigen Montageschritten die Hilfe einer zweiten Person in Anspruch zu nehmen.
- Sortieren Sie die Teile, und vergleichen Sie diese mit der Liste der in der Packung enthaltenen Teile.
- Bitte nehmen Sie im Verlauf des Zusammenbaus Sicherheitsmaßnahmen vor.

Im Verlauf des Zusammenbaus

Wenn Sie auf das Informationssymbol treffen, sehen Sie sich bitte den relevanten Montageschritt für weitere Kommentare und Hilfe an.



Dieses Symbol zeigt an, dass sich die installierende Person sich im Inneren des Produktes befinden sollte.



Dieses Symbol zeigt an, dass die installierende Person sich außerhalb des Produktes befinden sollte.

**Achtung:**

- Es ist wichtig, die Schrauben an der oberen Seite der Paneelkante einzudrehen und sich zu vergewissern, dass die Schrauben das Paneel durchdringen, um eine größtmögliche Strapazierfähigkeit zu gewährleisten.
- Bitte vergewissern Sie sich, dass Sie die untere Kante des Paneels in die Richtung des Schuppenbodens positionieren, und dass es den Boden einfasst.

Schritt 2: Platzieren Sie das Paneel für die hintere Wand auf dem Paneel des Fundaments des Schuppens, im Einklang mit der aufgedruckten Seriennummer (7700).

Schritt 18:

1. Bevor Sie die die Schraube einstecken, schieben Sie bitte das Profil ganz durch zum Anschlagpunkt mit der internen Arretierung.
2. Bitte beachten Sie, dass die Öffnungen in Teil 7402 nach unten zeigen müssen, ebenso wie die abgerundete Seite nach oben weisen sollte.

Schritt 29: Bitte beachten Sie, dass das Paneel und die Profile in der richtigen Richtung miteinander verbunden, und dass ebenso die Öffnungen der Profile der Illustration entsprechend korrekt platziert werden.

Schritt 38: Verankern Sie den Schuppen auf einer festen Oberfläche, und setzen Sie passende Schrauben und Dübel ein, die der Bodenart entsprechend.

* Die Firma liefert keine Dübel und Schrauben für den Verankerungsprozess.

IMPORTANT

Veillez lire ces instructions attentivement avant de commencer à assembler cet abri. Veillez suivre les étapes indiquées dans ces instructions. Conservez ces instructions dans un endroit sûr pour usage ultérieur.

Vous aurez besoin

(Ces articles ne sont pas fournis)

Sécurité

- ✓ Cet abri doit être placé et fixé à une surface nivelée pour garantir sa stabilité. Veillez à ce que les écrous et les ancrages soient compatibles avec le type de surface.
- ✓ Certaines pièces ont des bords métalliques. Faites attention en utilisant les pièces.
- ✓ Portez toujours des gants, des lunettes de protection et des manches longues pour monter ou réaliser une action de maintenance sur votre abri.
- ✓ Ne tentez pas de monter un jour de vent fort ou de basse température. Si vous utilisez un escabeau ou de l'outillage électrique, veillez à suivre les recommandations de sécurité du fabricant.
- ✓ Ne vous tenez pas sur le toit.
- ✓ N'entreposez pas des objets chauds comme des grills récemment utilisés, des chalumeaux, etc... dans l'abri.
- ✓ Des articles lourds ou pointus ne doivent pas être posés contre les panneaux muraux.
- ✓ Pour éviter tout étouffement, ne laissez pas les enfants jouer avec les matériaux d'emballage.
- ✓ Abri doit être fixé par le forage à travers des panneaux de plancher trous endroits et l'insertion des vis adéquates dans le sol

Avant de commencer

- ✓ Consultez les autorités locales concernant les limites ou les permis de construction nécessaires pour construire cet abri de jardin.
- ✓ Complétez la préparation du site avant de déballer les parties et de commencer le montage.
- ✓ Il est fortement recommandé de vous aider d'une seconde personne pour certaines étapes.
- ✓ Ordonnez les pièces et vérifiez-les avec la liste des pièces contenues.
- ✓ Veillez prendre des précautions de sécurité pendant le montage.

Pendant le montage

Lorsque vous voyez l'icône Information, veillez regarder l'étape de montage pertinente pour voir des commentaires et une assistance supplémentaires.



Cette icône indique que l'installateur doit être à l'intérieur du produit



Cette icône indique que l'installateur doit être en dehors du produit.

**Attention:**

- ✓ Il est important de visser les écrous en haut de la crête du panneau et de vous assurer que les vis pénètrent à travers le panneau afin d'obtenir une durabilité maximale.
- ✓ Assurez-vous de positionner la crête inférieure du panneau vers le sol de l'abri et qu'il le referme.

Etape 2: Placez le panneau mural arrière sur le panneau de base de l'abri selon le numéro de série (**pièce 7700**).

Etape 18:

1. Avant de connecter la vis, veillez faire glisser le profil jusqu'au point de rencontre avec le frein interne.
2. Veillez remarquer que les trous de la pièce **7402** doivent être vers le bas et le côté arrondi doit être vers le haut.

Etape 29: Remarquez les profils et les panneaux connectés dans la bonne direction ainsi que les trous des profils correctement placés comme illustré.

Etape 38: Ancrez l'abri sur une surface solide et utilisez des vis et des connexions convenables selon le type de sol.

*La compagnie ne fournit pas les connexions et les écrous pour l'étape d'ancrage.

Ne serrez pas les vis et les boulons (411 & 412) jusqu'à la fin du processus de montage. Ces 2 icônes indiquent s'il est nécessaire de serrer les écrous ou non.

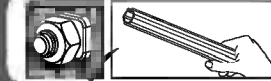

412



411



DŮLEŽITÉ

Dříve než začnete kůlnu sestavovat, přečtěte si pozorně tyto instrukce. Dodržujte postup v pořadí, v jakém je uveden v těchto instrukcích. Uložte si tyto instrukce na bezpečné místo pro budoucí použití.

Budete potřebovat

(tyto položky nejsou součástí dodávky)

Bezpečnost

- Tato kůlna musí být umístěna a zajištěna na vyvýšeném povrchu, aby bylo možné zajistit stabilitu.
- Ujistěte se, že šrouby a kotvy jsou kompatibilní s typem povrchu.
- Některé části mají kovové okraje. Při manipulaci se součástkami buďte opatrní.
- Při sestavování nebo údržbě kůlny noste vždy rukavice, chrániče očí a dlouhé rukávy. Nepokoušejte se kůlnu sestavovat při velkém větru nebo za chladného počasí. Pokud používáte
- štafle nebo elektrické nástroje, ujistěte se, že dodržujete bezpečnostní doporučení výrobce.
- Nestoupejte si na střechu.
- Neukládejte horké položky jako jsou nedávno používaný gril, letovací lampa, atd.
- Těžké nebo ostré předměty by neměly být položeny směrem ke zdi.
- Pro vyhnutí se riziku udušení, nedovolte dětem, aby si hrály s obaly.
- Bouda musí být zajištěn provrtání stropní panelu otvory místa a vložení vhodných šroubů do země

Než začnete

- Informujte se u místních orgánů na případná stavební omezení nebo požadovaná povolení pro výstavbu této zahradní kůlny.
- Než vybalíte jednotlivé díly a začnete kůlnu sestavovat, připravte si prostor, kam ji umístíte.
- Velmi se doporučuje, abyste při některých krocích měli k ruce druhého člověka.
- Vyndejte jednotlivé součástky a zkontrolujte obsah dle seznamu součástek.
- Při sestavování dodržujte bezpečnostní instrukce.

Během sestavování

Jakmile narazíte na informační ikonu, podívejte se na příslušný krok, kde najdete další komentáře a rady.



Tato ikona ukazuje, že osoba sestavující kůlnu by měla být uvnitř objektu



Tato ikona ukazuje, že člověk sestavující kůlnu by se měl nacházet vně objektu.

**Pozor:**

- It je důležité zavrtat šrouby na horní hřbet panelu a ujistit se, že šrouby prošly panelem a budou mít maximální výdrž.
- Ujistěte se, že spodní hřbet panelu leží na podlaze kůlny a že ji uzavírá.

Krok 2: Umístěte zadní panelovou stěnu na základní panel kůlny, dle vytištěných sériových čísel (část 7700).

Krok 18:

1. Než propojíte pomocí šroubu, posuňte profil po celé délce skrz bod, kde se setkává s vnitřní brzdou.
2. Dejte pozor, aby otvory v části 7402 byly čelní stranou dolů, kulatá část může být naopak otočena nahoru.

Krok 29: Dejte pozor, aby panely a profily byly propojeny správným směrem a otvory profilů byly správně umístěny tak, jak je to zobrazeno na obrázku.

Krok 38: Upevněte kůlnu na pevný povrch pomocí vhodných šroubů a přípojek v závislosti na podkladu.

*společnost neposkytuje šroubky a přípojky pro upevnění podlahy.

Neutahujte šrouby a matky, (411 & 412) dokud kůlnu zcela nesestavíte. Tyto 2 ikony ukazují, zda je vyžadováno utahování šroubů či nikoliv.

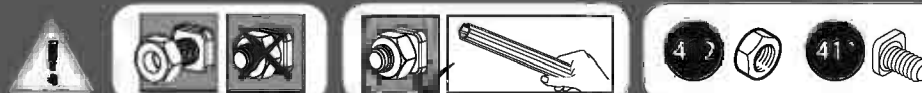

IMPORTANTE

Leggere queste istruzioni con attenzione prima di iniziare a montare questo capanno. Eseguire i passi nell'ordine indicato in queste istruzioni. Tenere queste istruzioni in un luogo sicuro per consultazione futura.

Occorreranno

(questi oggetti non sono forniti)

Sicurezza

- Questo capanno deve essere sistemato e fissato a una superficie piana per assicurare la sua stabilità. Accertarsi che le viti e i tasselli siano compatibili con il tipo di superficie.
- Alcune parti hanno bordi di metallo. Fare attenzione quando si maneggiano le componenti.
- Indossare sempre guanti, protezione per gli occhi e maniche lunghe quando si monta o si eseguono operazioni di manutenzione sul capanno.
- Non provare a montare in giorni con forte vento o basse temperature. Se si usa una scala a libretto o utensili elettrici accertarsi di seguire le avvertenze di sicurezza del produttore.
- Non stare in piedi sul tetto.
- Non immagazzinare oggetti caldi come piastre di cottura usate di recente, fiamme ossidriche ecc. nel capanno.
- Articoli pesanti o taglienti non devono essere appoggiati contro i pannelli delle pareti.
- Per evitare soffocamento, non consentire a bambini di giocare con i materiali di imballaggio.
- Capannone deve essere garantito da perforazione attraverso pannelli a pavimento fori località e inserendo le viti adeguate nel terreno

Prima di cominciare

- Consultare le autorità locali per quanto riguarda limitazioni o permessi di costruzione necessari per costruire questo capanno per il giardino.
- Completare la preparazione del sito prima di disimballare le parti e cominciare a montare.
- È caldamente raccomandato l'aiuto di una seconda persona in alcune fasi.
- Ordinare le parti e controllare confrontando con l'elenco delle parti contenute.
- Adottare precauzioni di sicurezza durante il montaggio.

Durante il Montaggio

 Quando si incontra l'icona delle informazioni, fare riferimento al passo di montaggio rilevante per ulteriori commenti e assistenza.

 Questa icona indica che l'installatore deve essere all'interno del prodotto

 Questa icona indica che l'installatore deve essere all'esterno del prodotto

Attenzione:

- È importante fare i fori per le viti nella parte superiore del pannello e accertarsi che le viti penetrino attraverso il pannello per la massima resistenza.
- Accertarsi di posizionare la parte inferiore del pannello verso il pavimento del capanno e che questo lo racchiuda.

Passo 2: Mettere il pannello del muro posteriore sul pannello di base del capanno secondo il numero di serie stampato (**parte 7700**).

Passo 18:

1. Prima di collegare la vite, fare scivolare il profilo fino alla fine attraverso il punto di incontro con il freno interno.
2. Notare che i fori nella **parte 7402** devono essere rivolti verso il basso, e che il lato arrotondato deve essere rivolto verso l'alto.

Passo 29: Notare che il pannello e i profili siano collegati nella direzione giusta e che i fori dei profili siano sistemati in modo corretto come illustrato.

Passo 38: Fissare il capanno su una superficie salda e usare viti e attacchi adatti secondo il terreno.



*L'azienda non fornisce attacchi e viti per la fase di fissaggio.

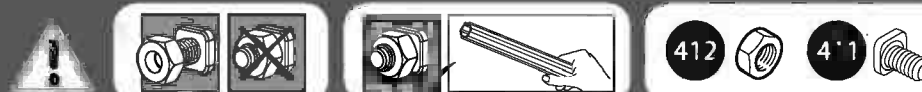

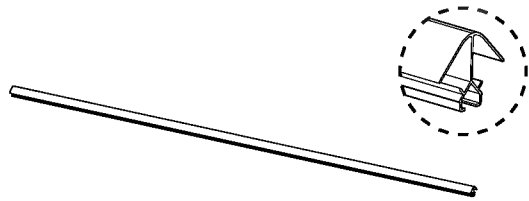
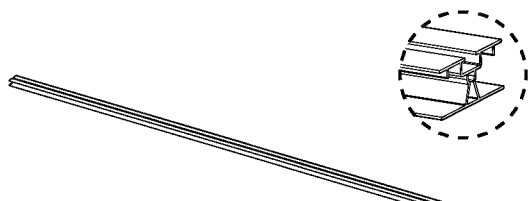
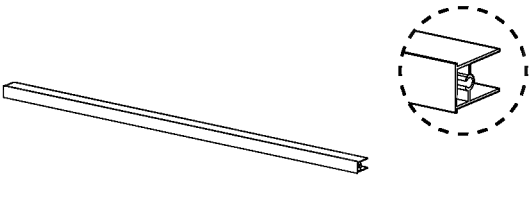
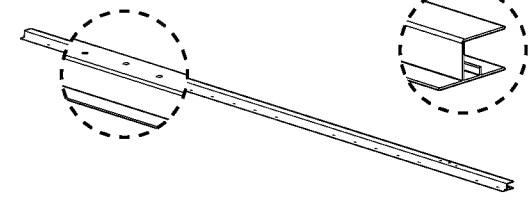
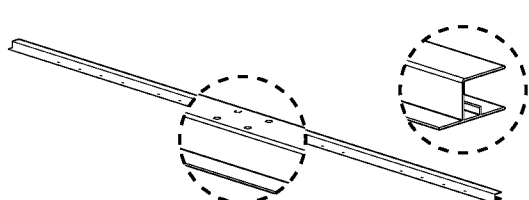

Non serrare viti e dadi (411 & 412) fino alla fine del processo di assemblaggio. Queste 2 icone indicano se è necessario o meno serrare le viti

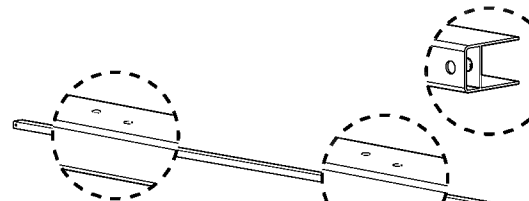
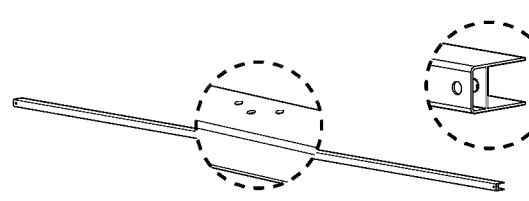
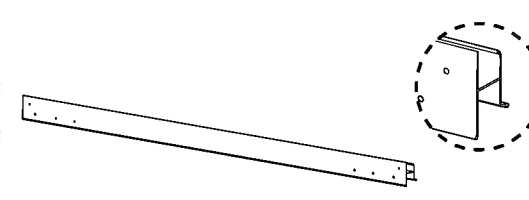
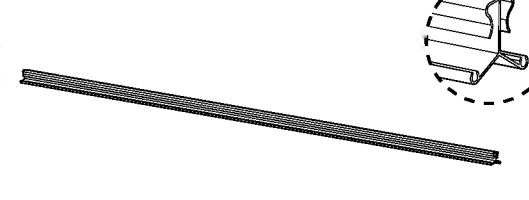
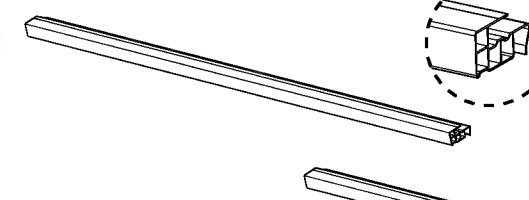



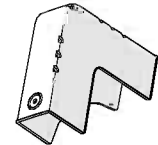
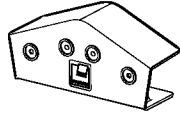

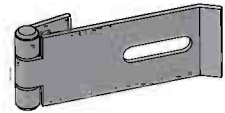
Contents



Item		Qty.
7733		4
7732		2
7726		2
7725		1
7724		1

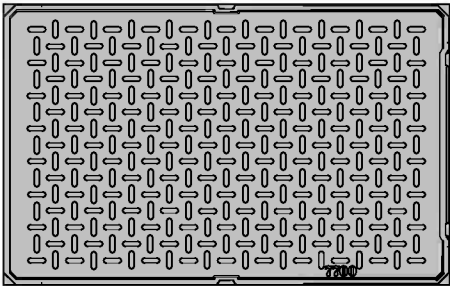

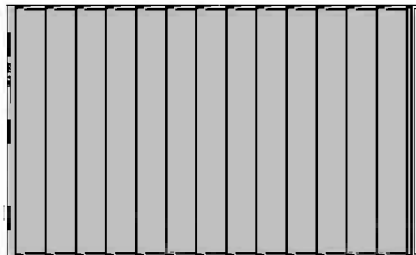

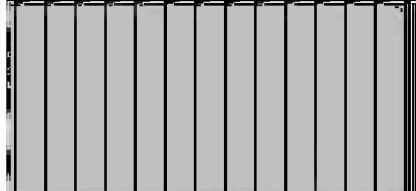
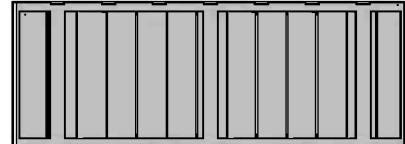
Item		Qty.
7381		1
7379		1
7723		2
7731		1
7734		2
7366		4

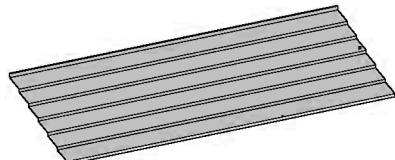

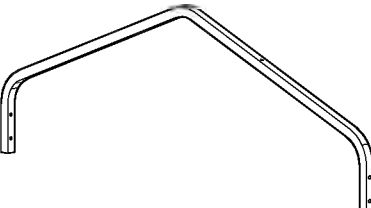

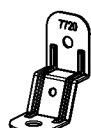
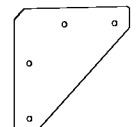
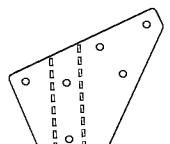



Item		Qty.
7402		4
7403		2
7356		2
7355 A		1
7355 B		1
T001		1

Contents

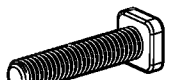
Item		Qty.
7700		1
7388		2
7703		1
7706		2
7704		4
7702		1

Item		Qty.
7740		2
7717		1
7719		1

7720		6
7400		2
7721		4
428		4 (+1)
4036		2
431		6 (+1)
422		6 (+2)

Item		Qty.
411		14 (+2)
466		18 (+2)
7284		4 (+1)
7441		52 (+3)
7442		20 (+2)
7444		17 (+2)
7566		2
7524		1
7445		8 (+2)

1

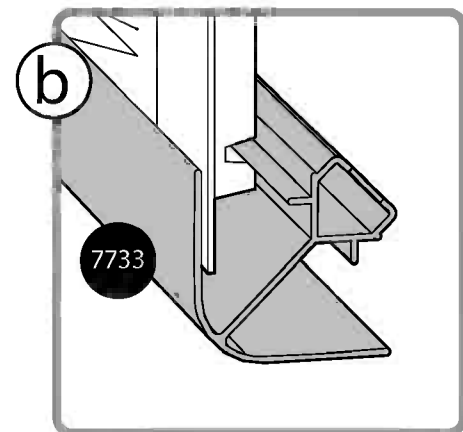
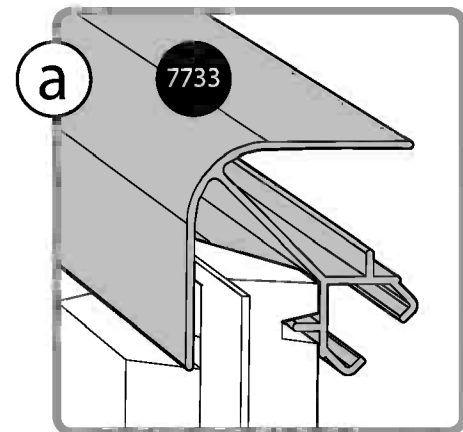
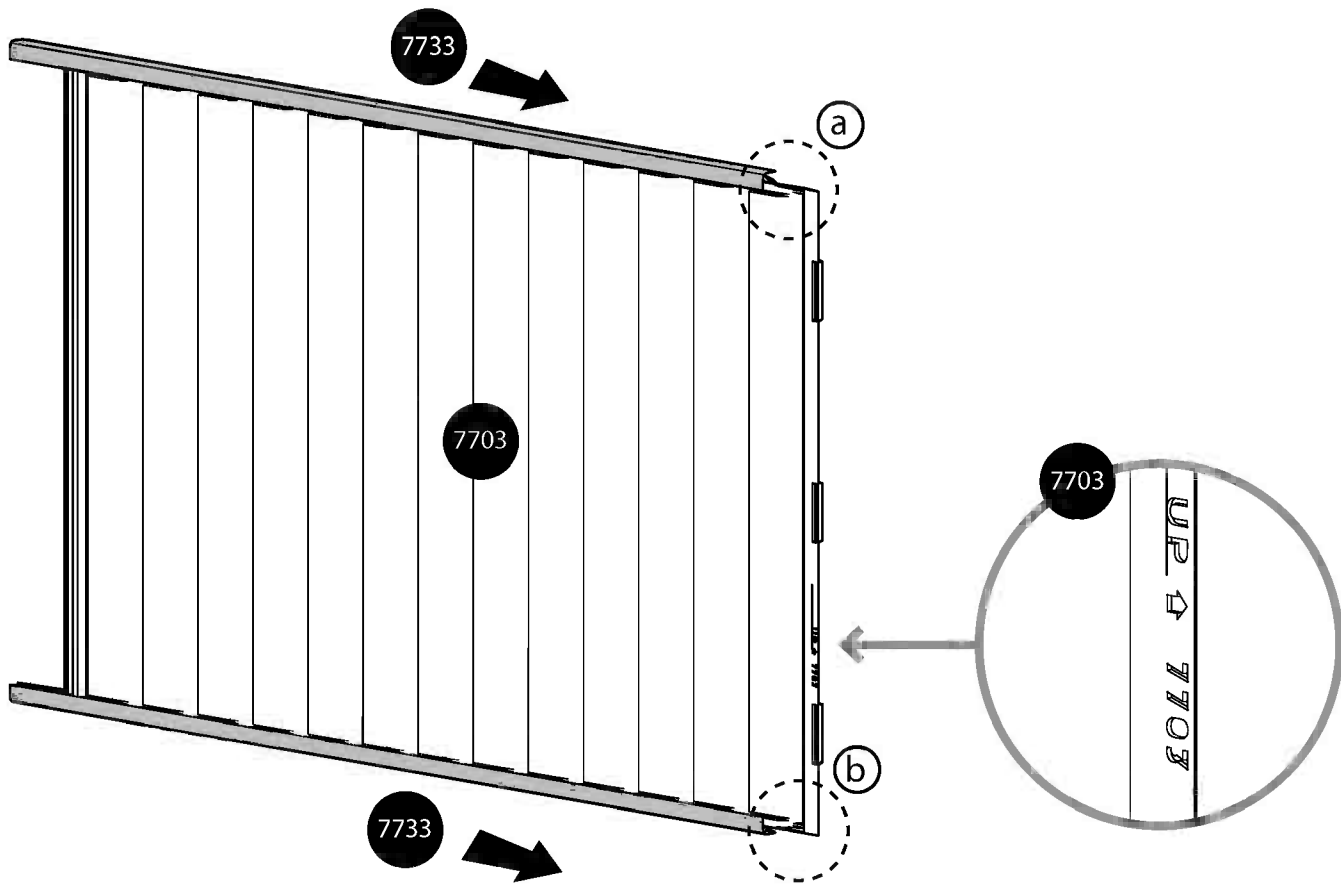
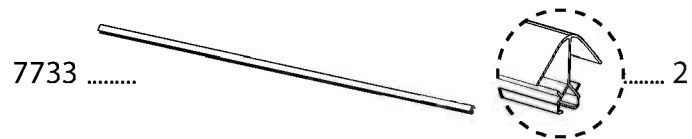
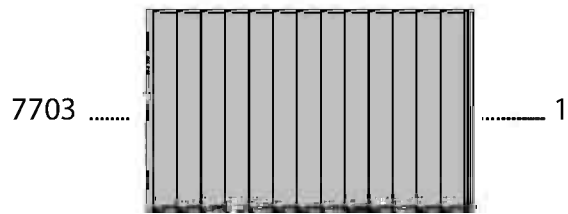



7700 1

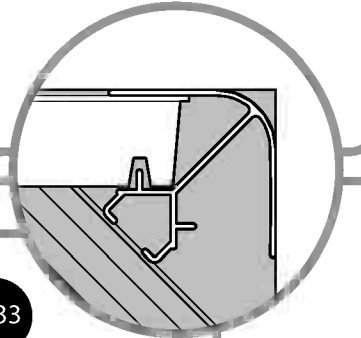
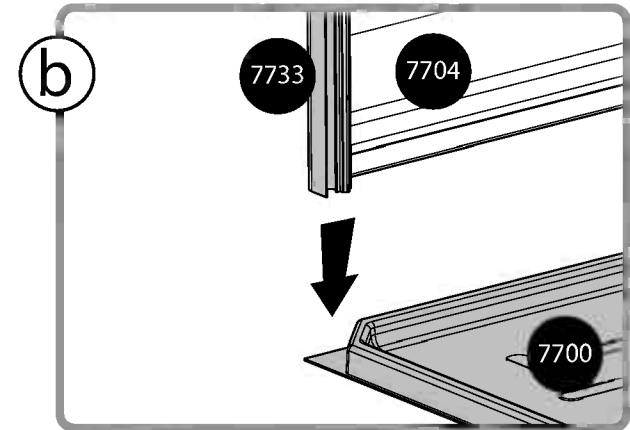
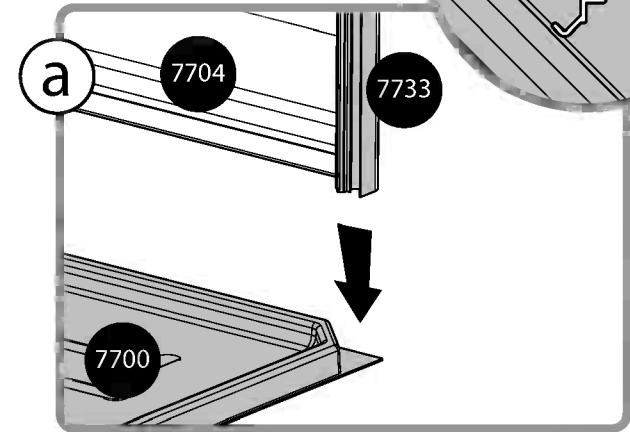
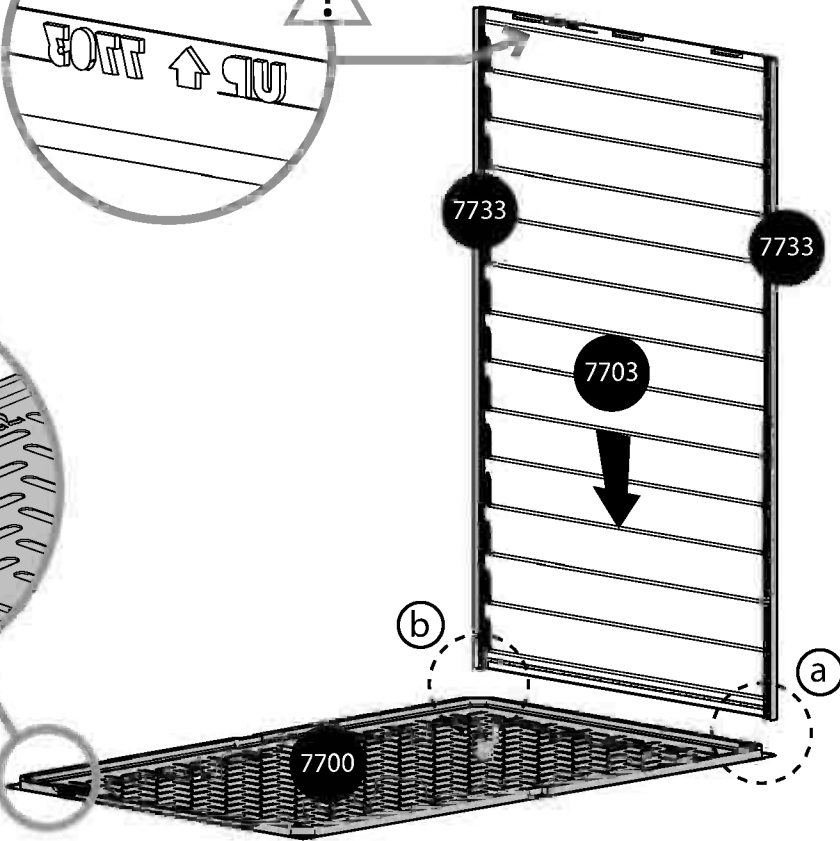
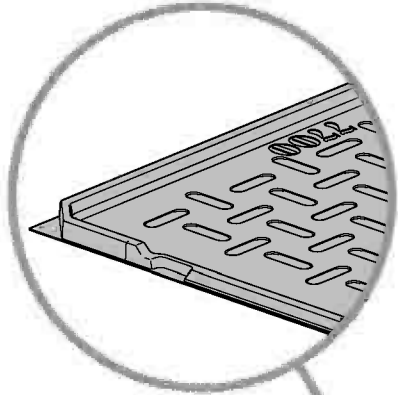
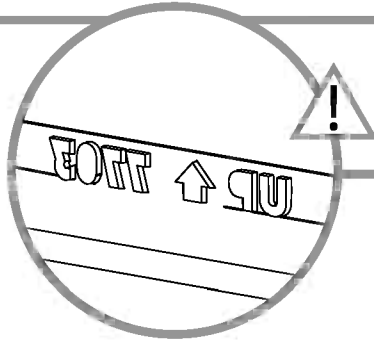
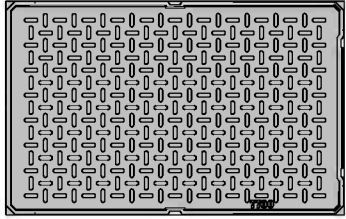

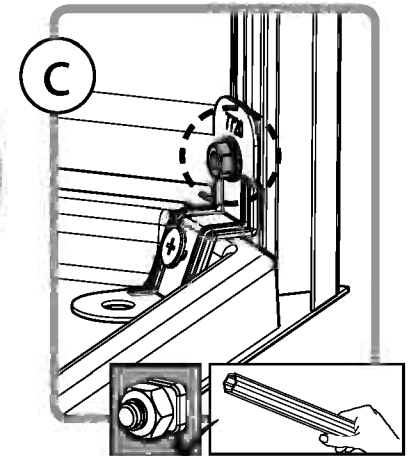
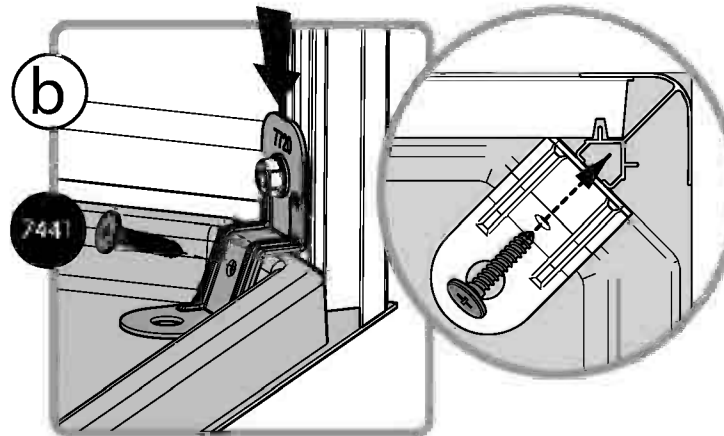
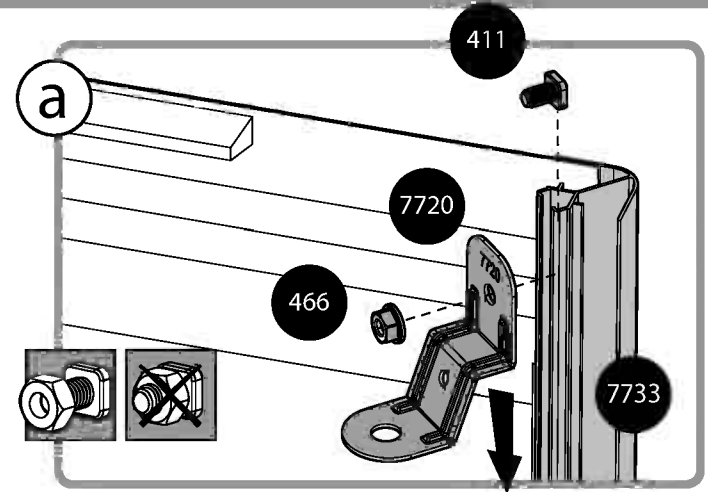
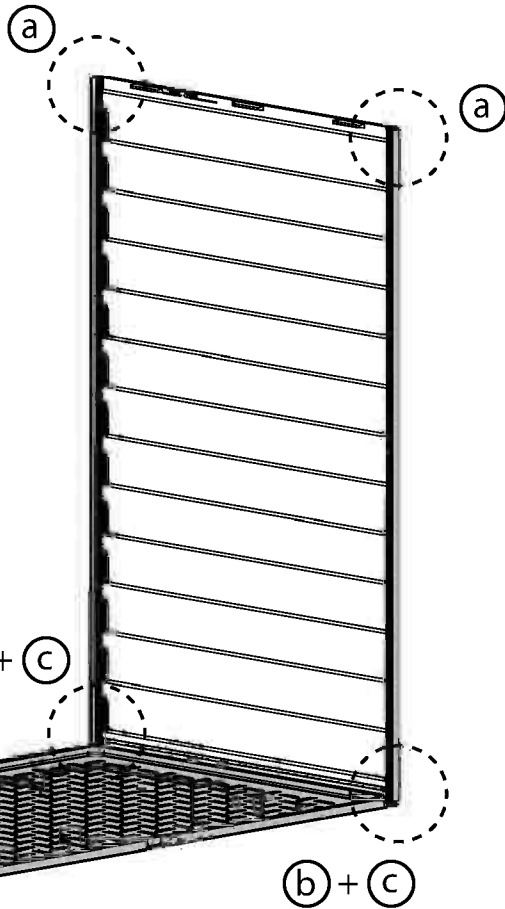
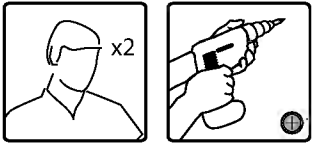
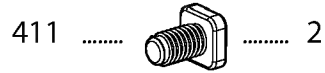
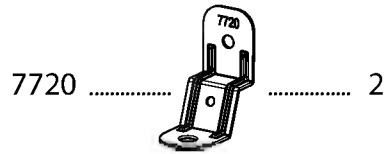

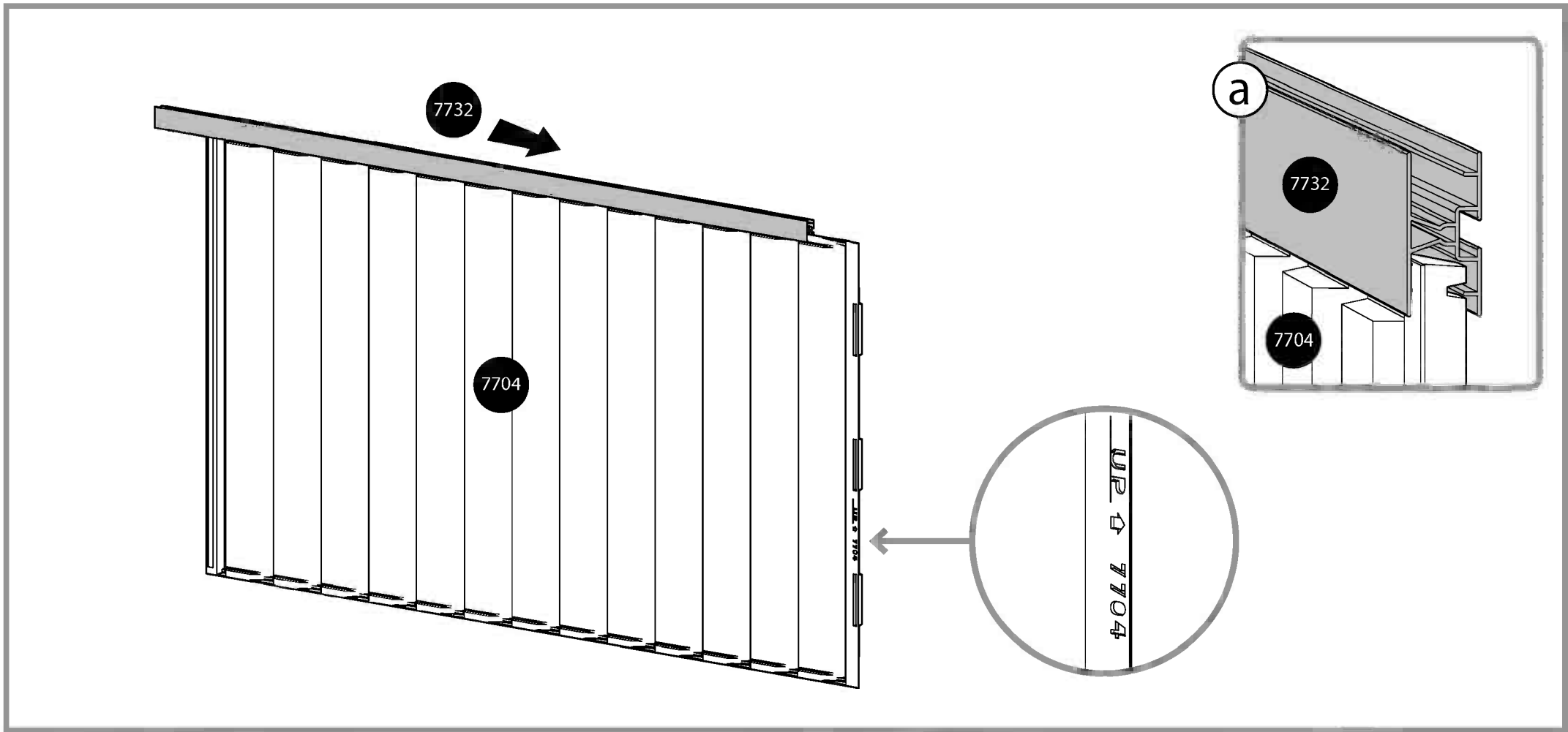
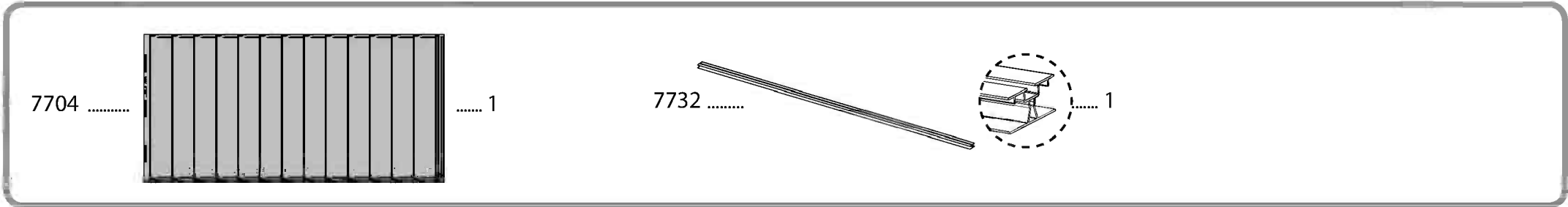



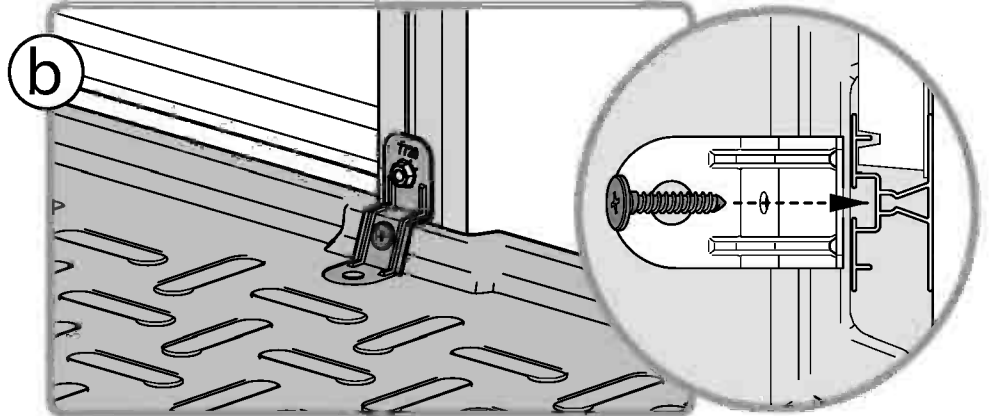
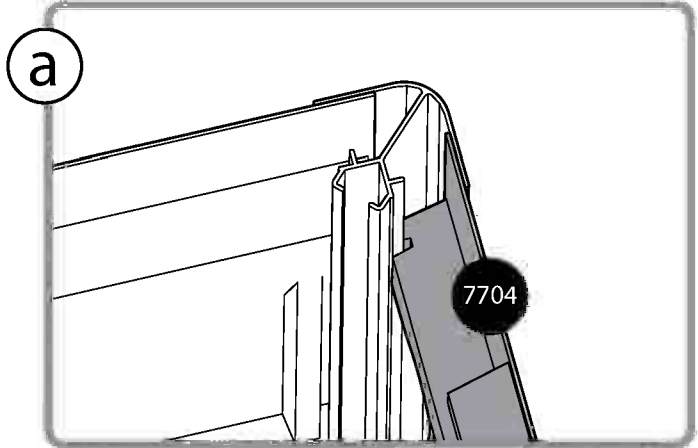
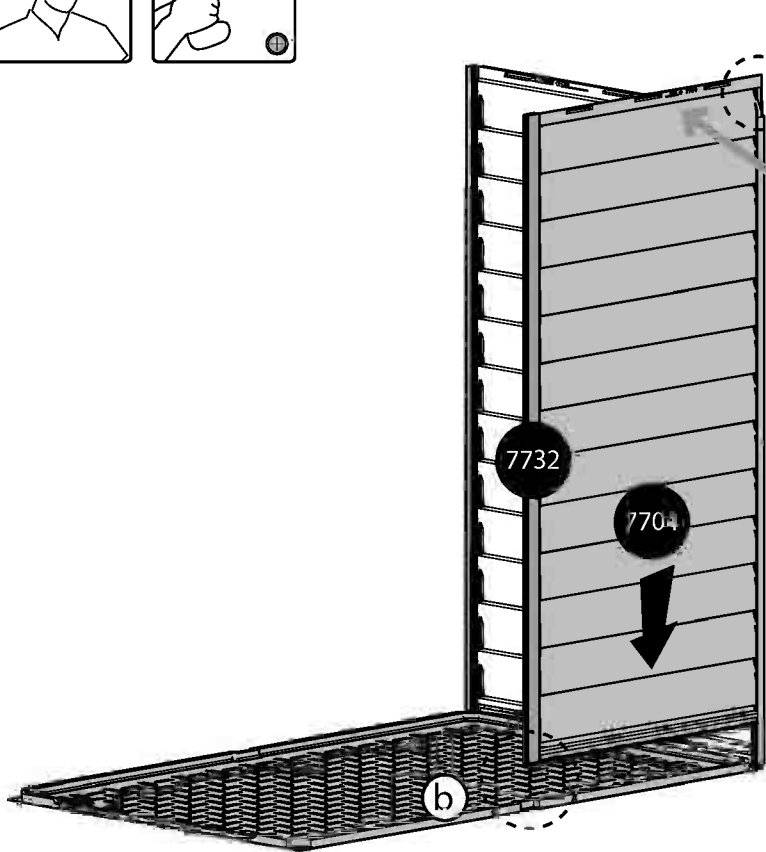
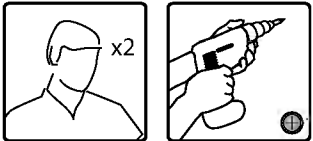

7720 1 411 1 466 1 7441..... 1

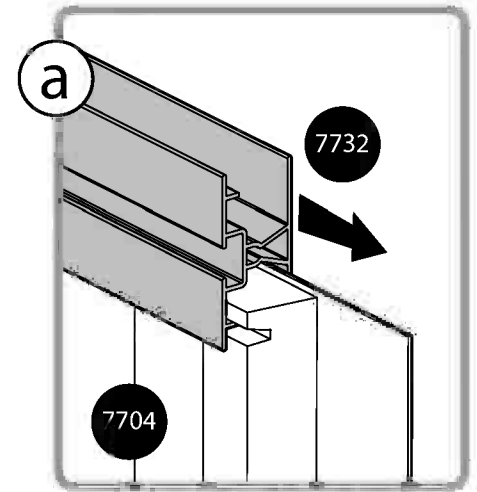
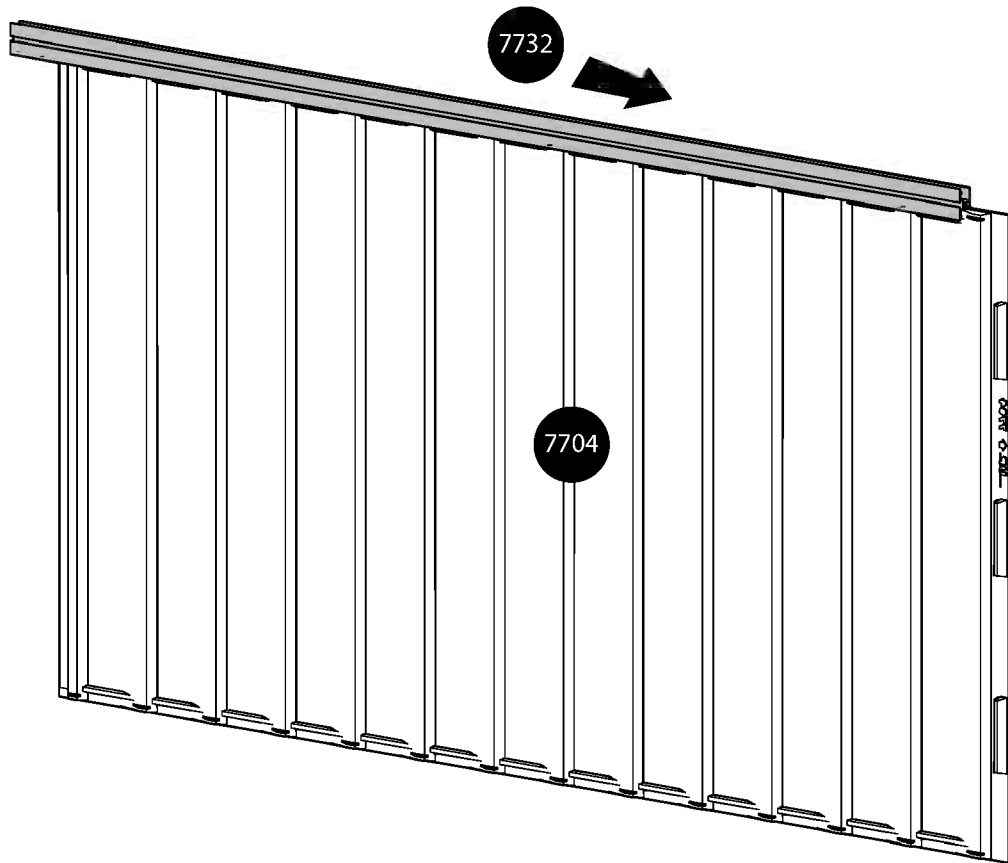
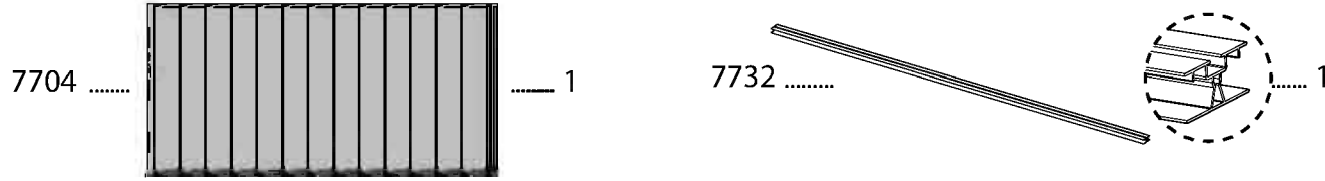

6





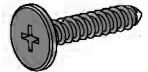

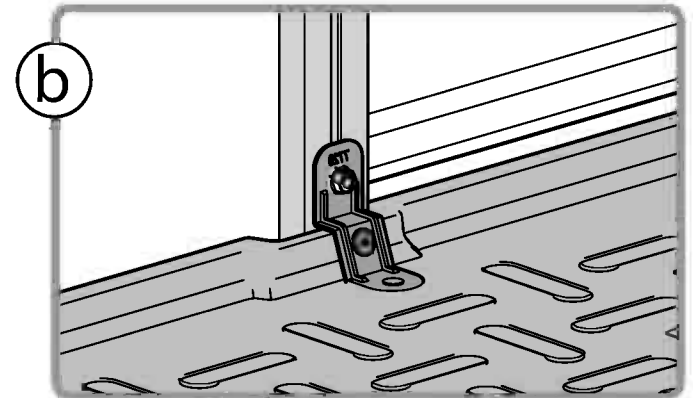
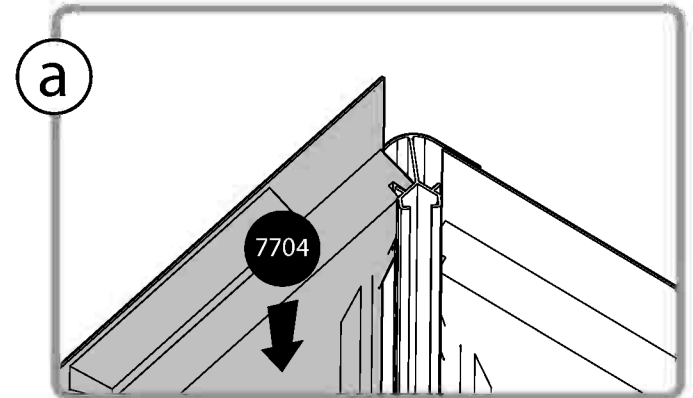
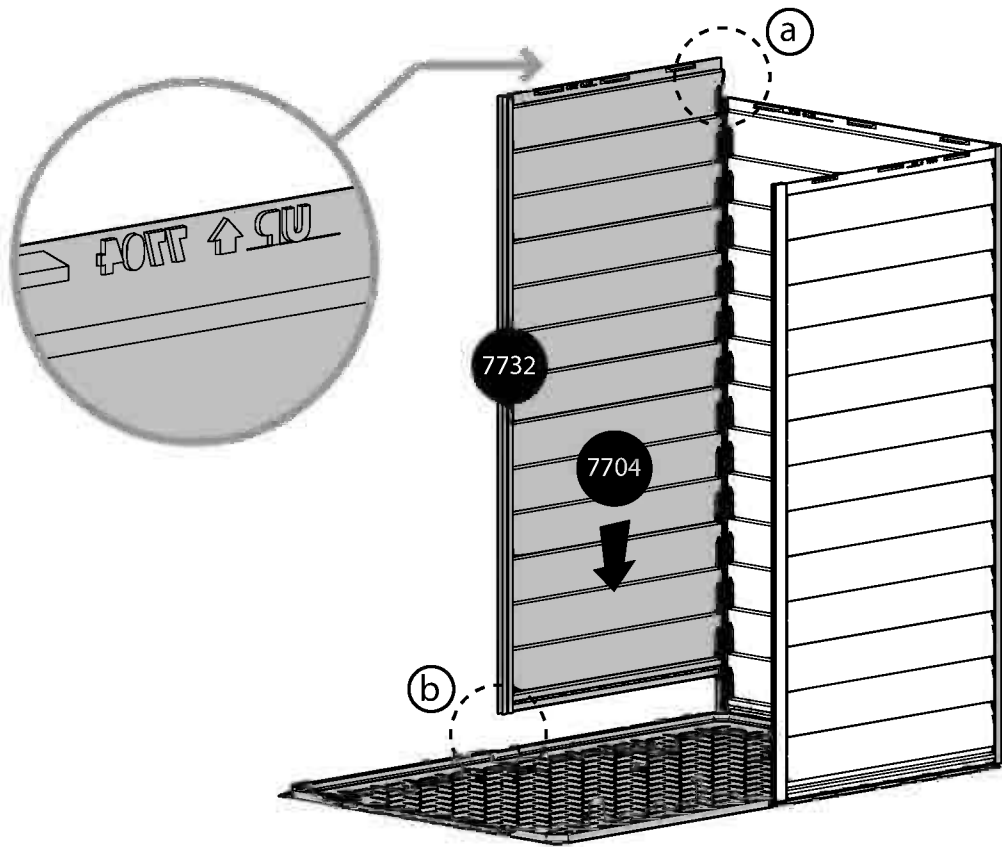
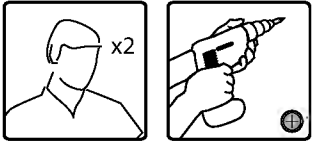
- 7720  1 411  1 466  1 7441.....  1

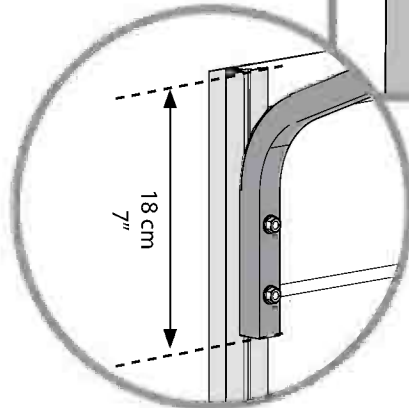
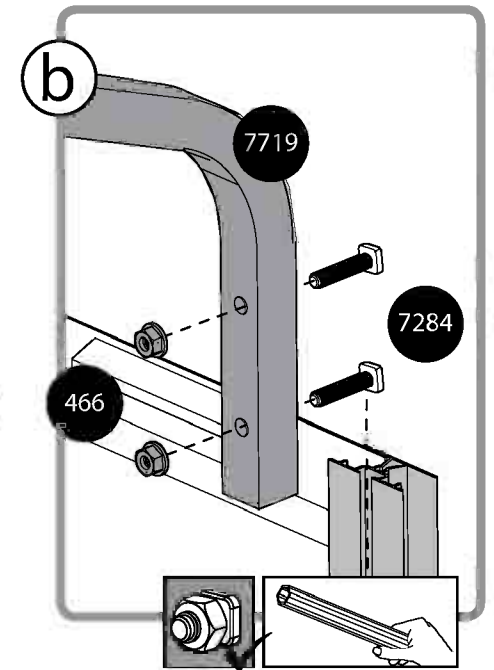
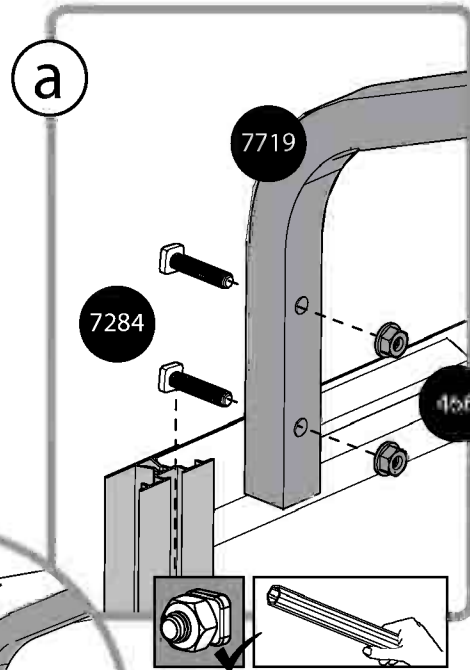
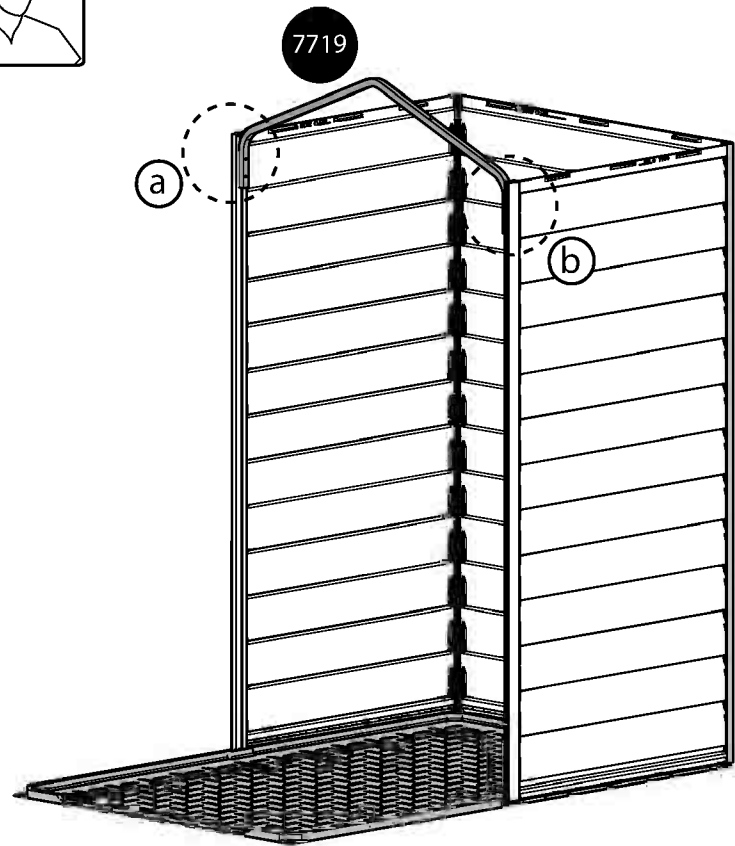
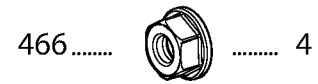
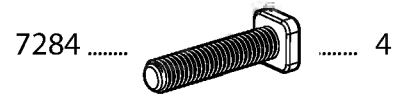
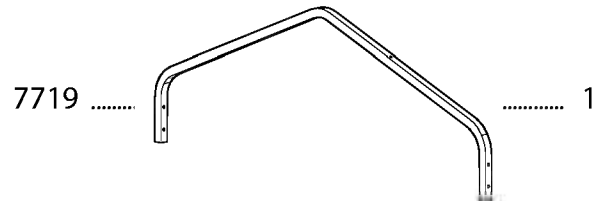

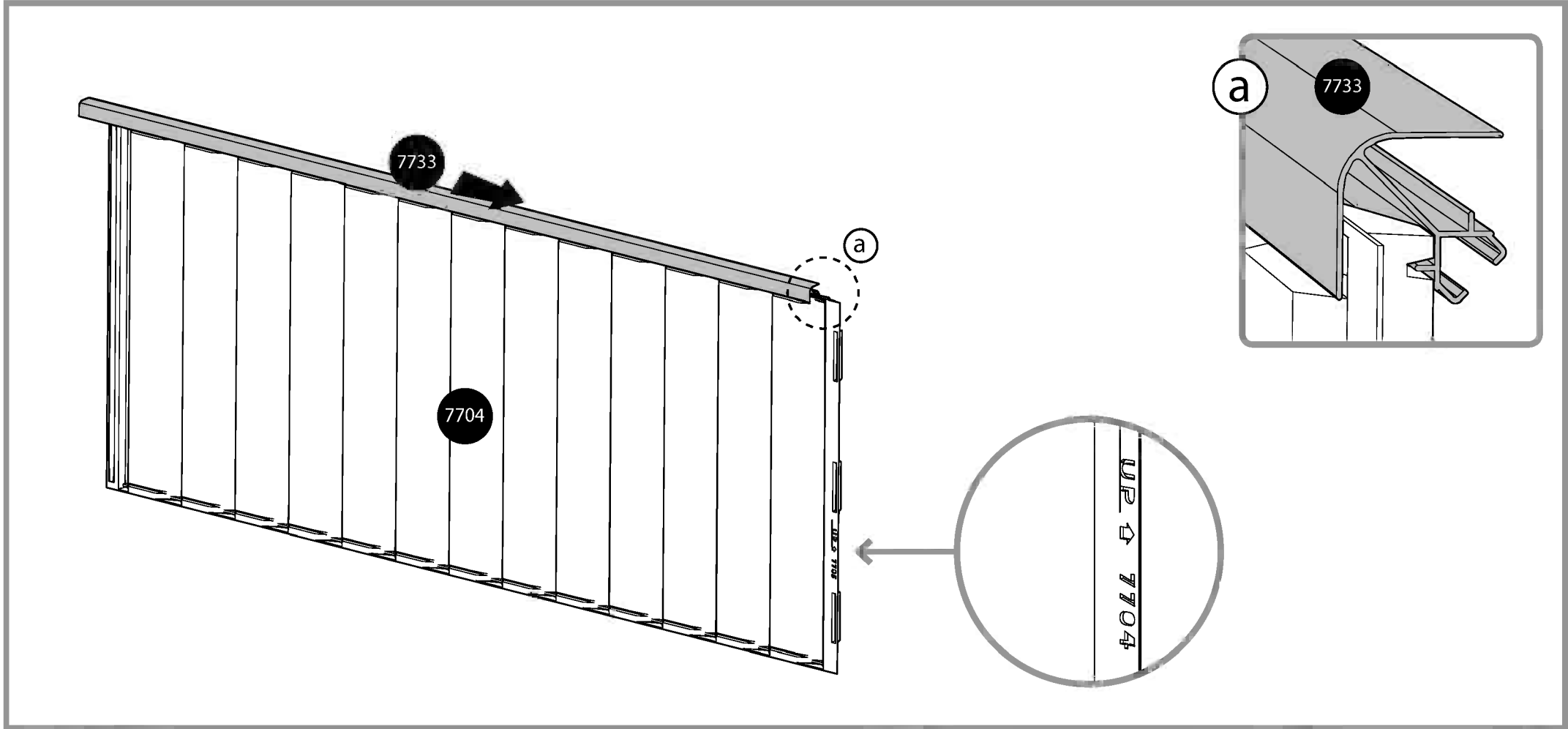
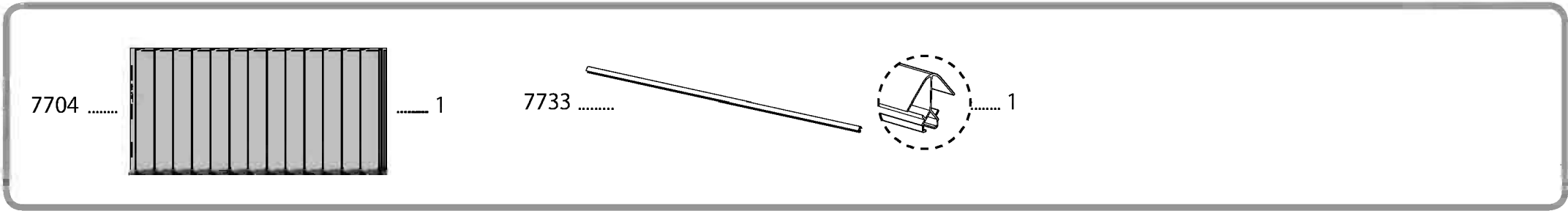



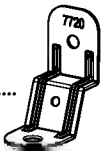

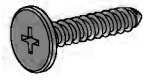

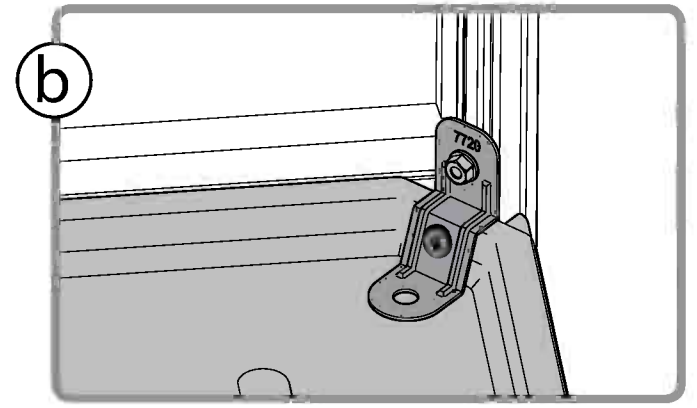
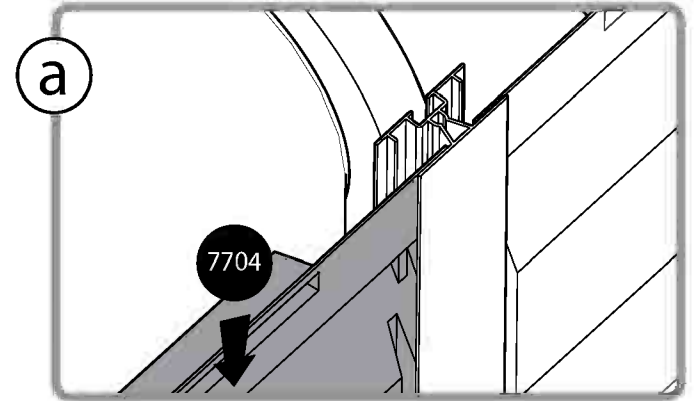
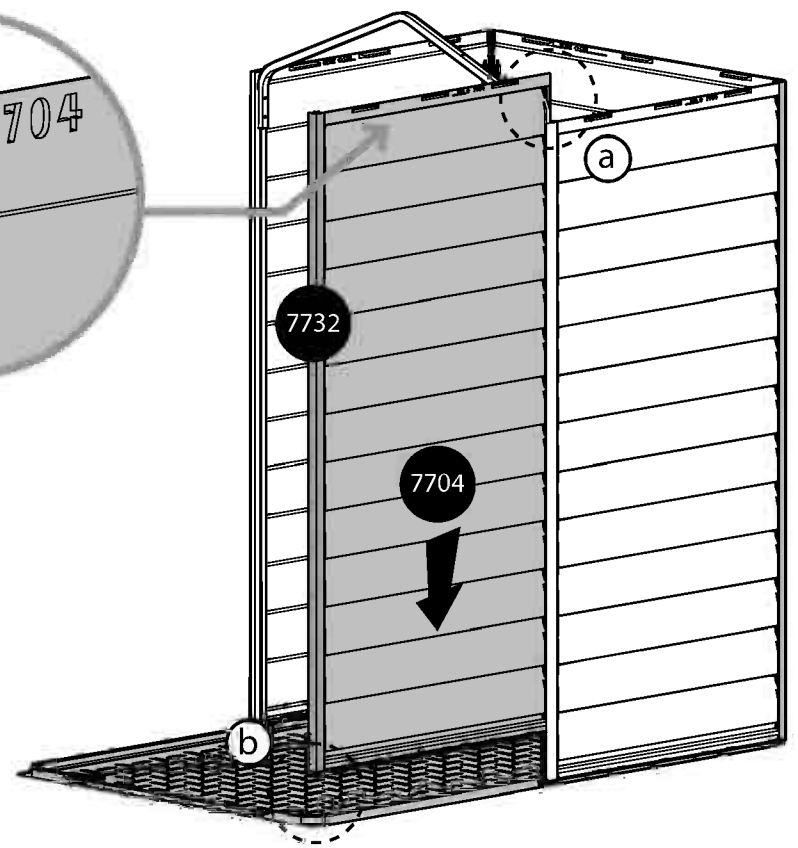
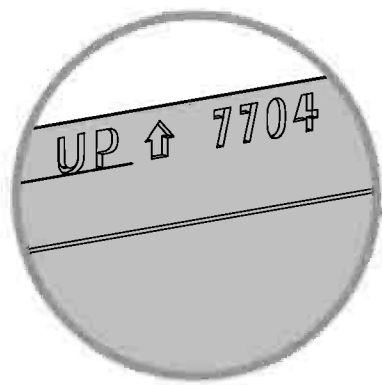
- 7720  1
- 411  1
- 466  1
- 7441.....  1

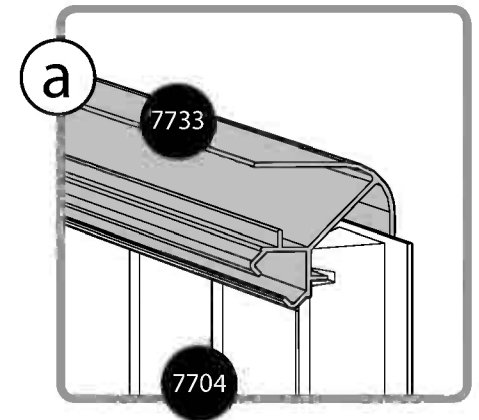
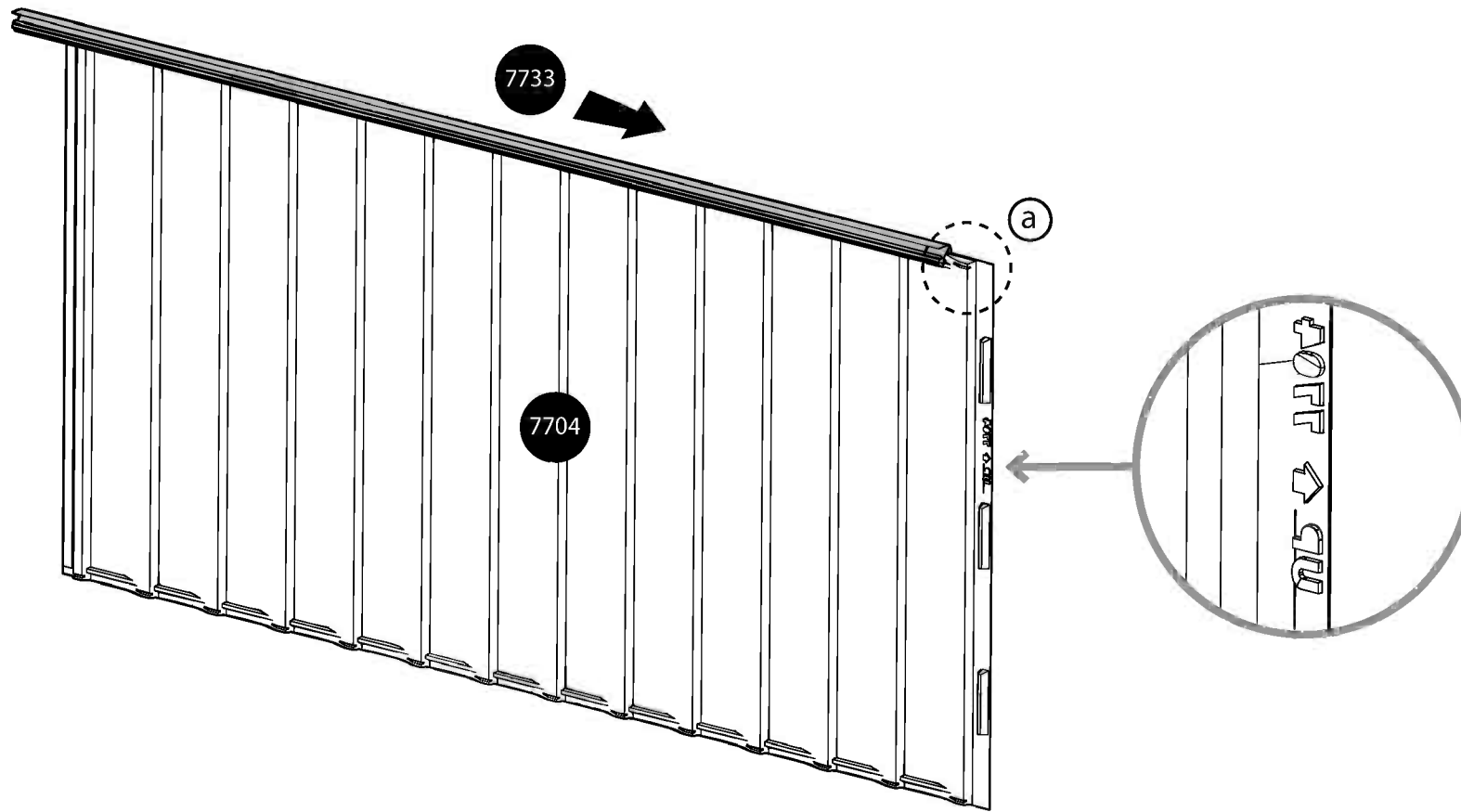
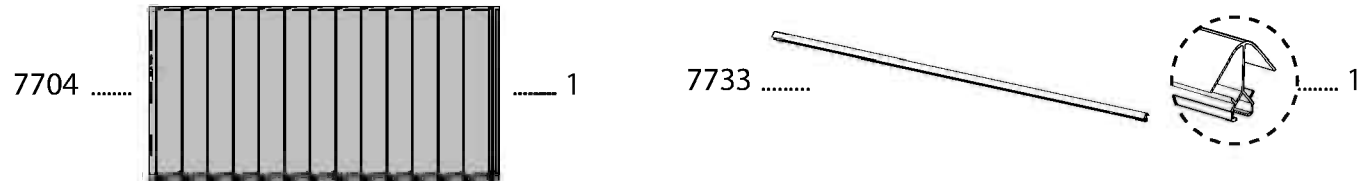



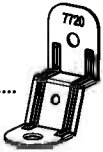

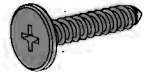
- 7720  1 411  1 466  1 7441.....  1

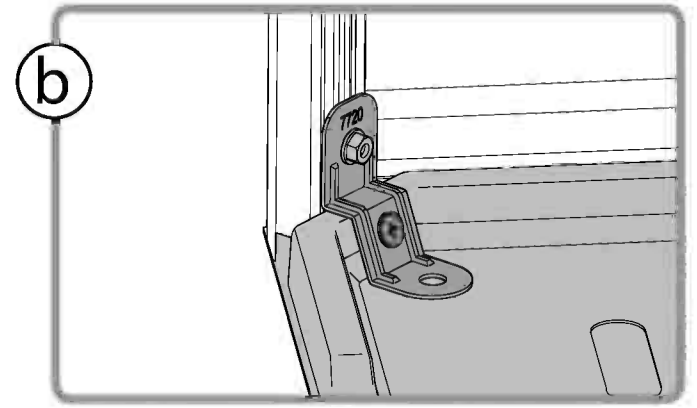
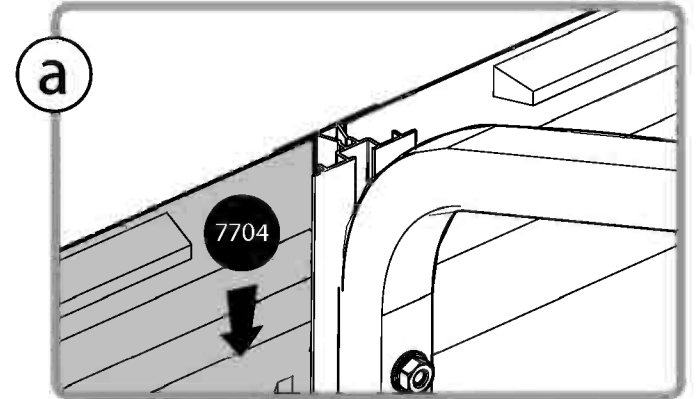
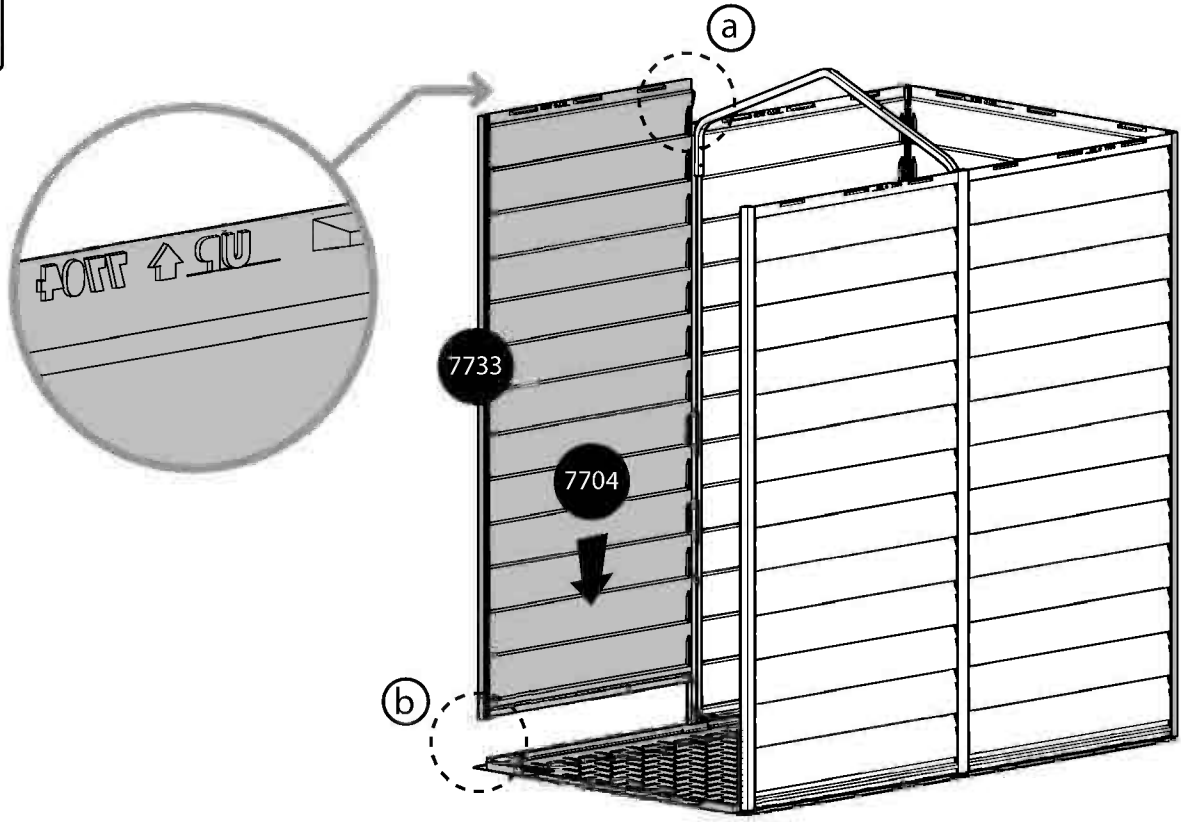
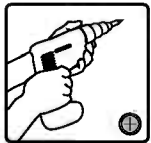

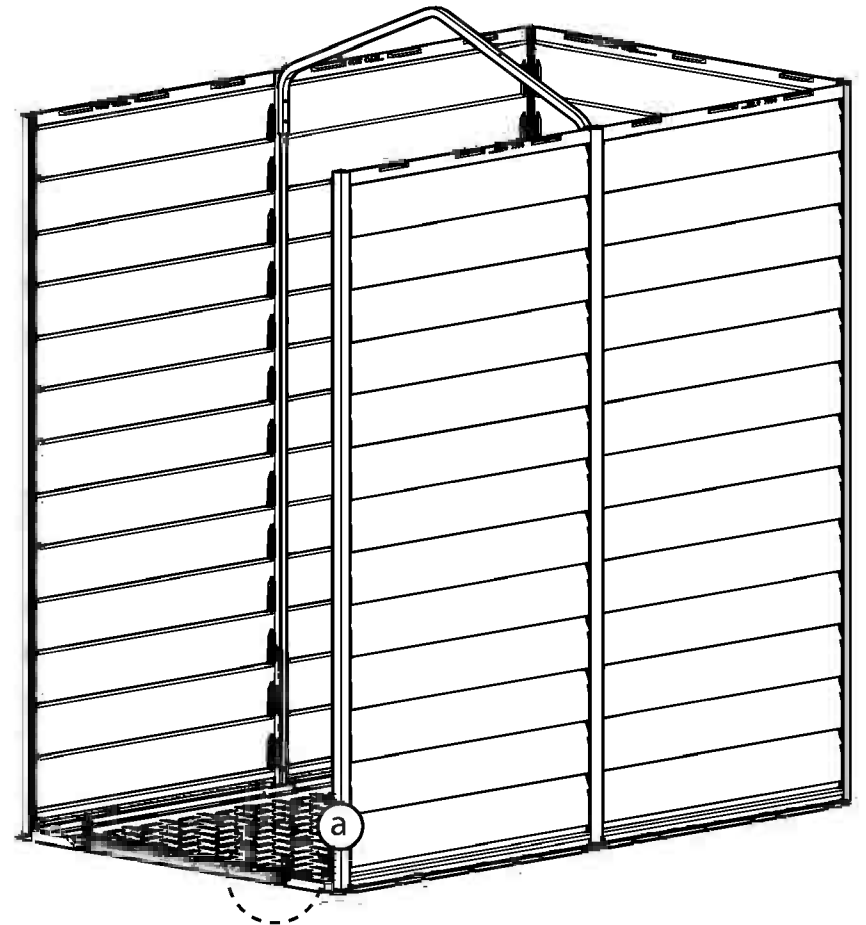
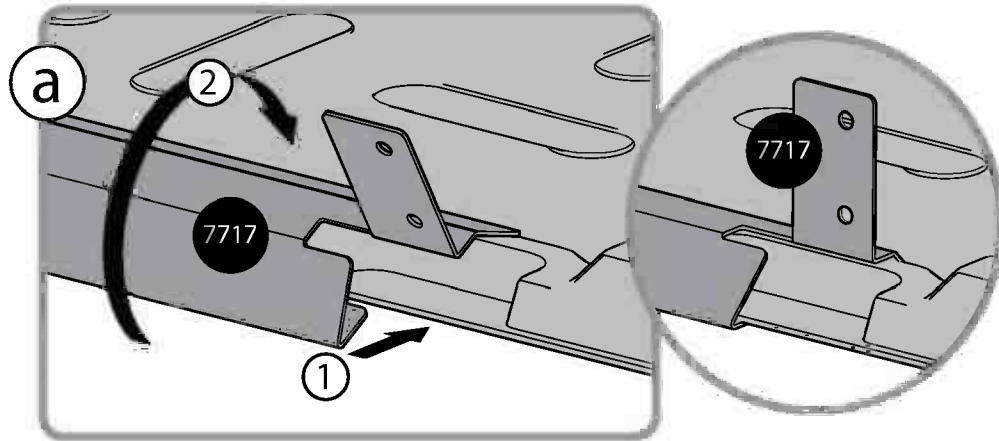



7706 2



7725

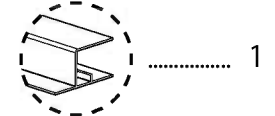

1

7724

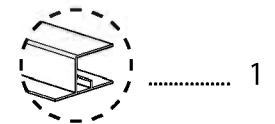
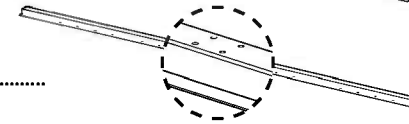

1

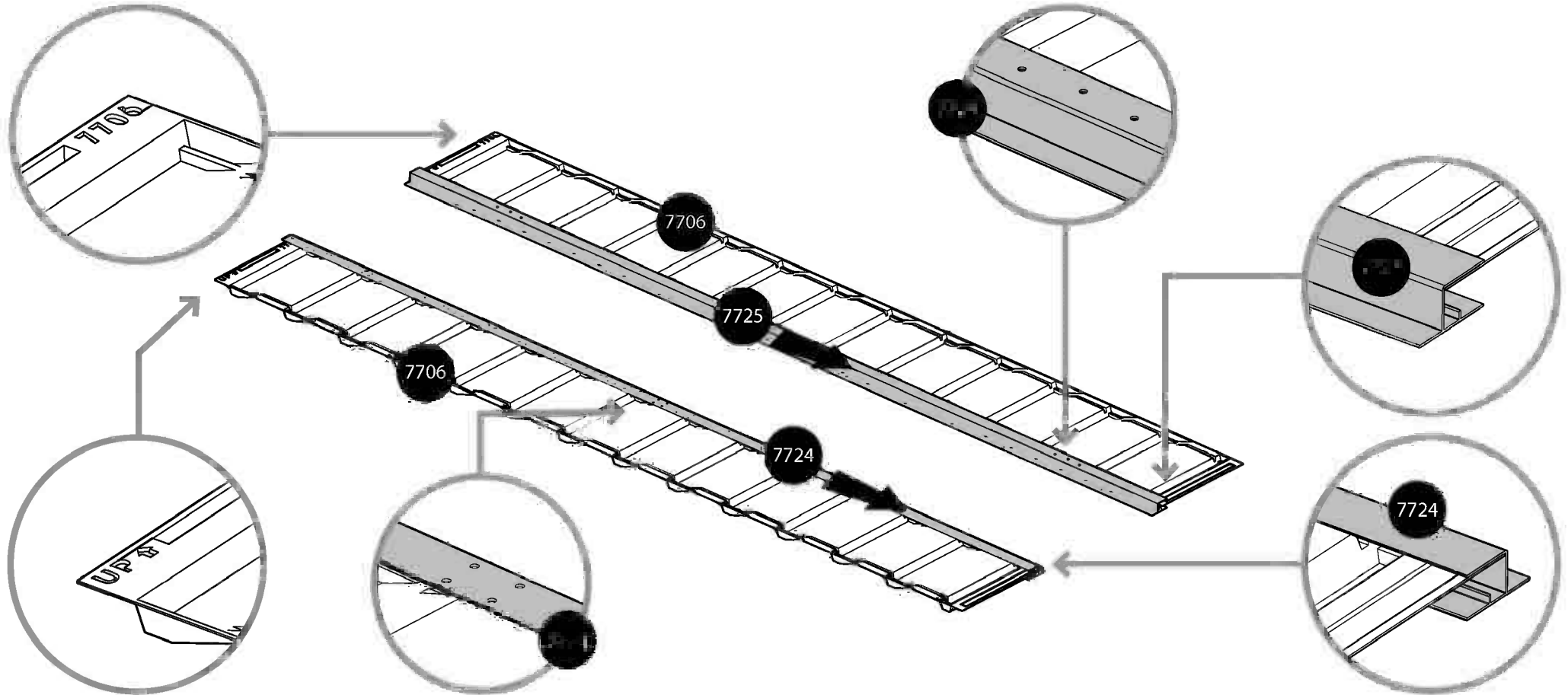





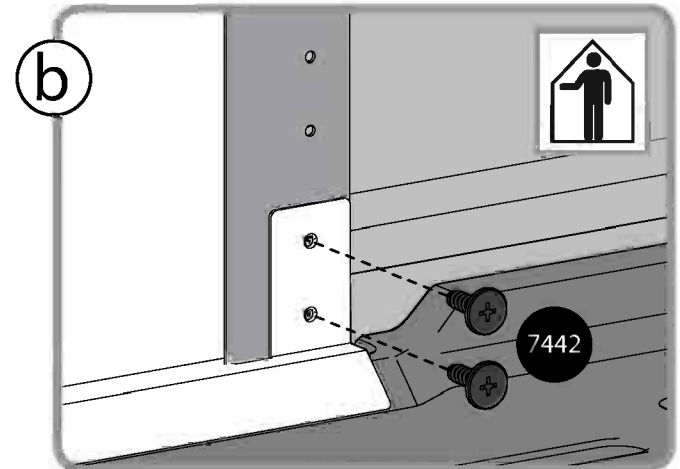
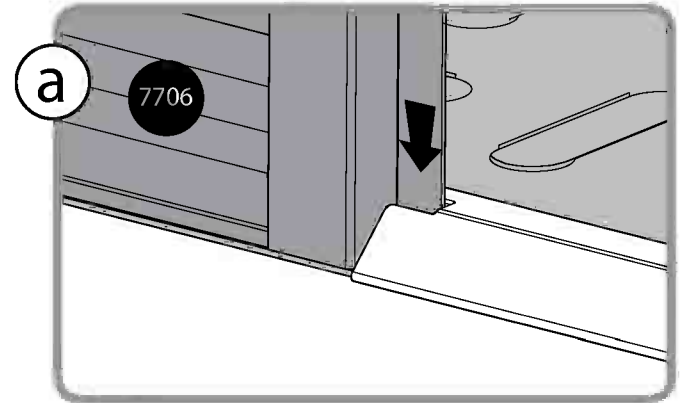
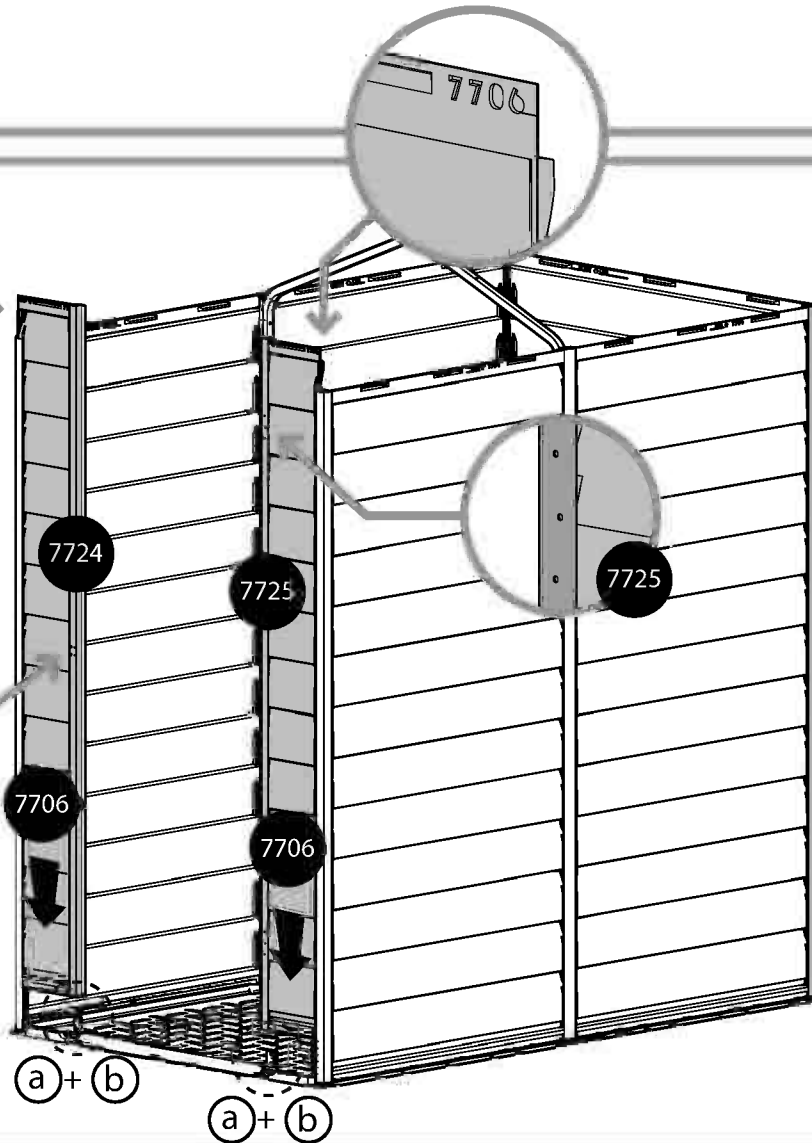
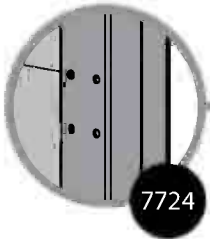
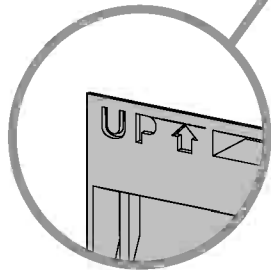
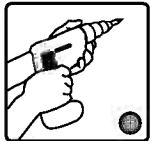

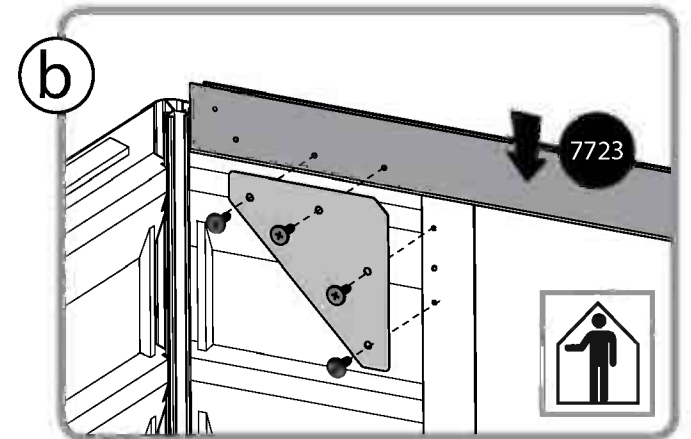
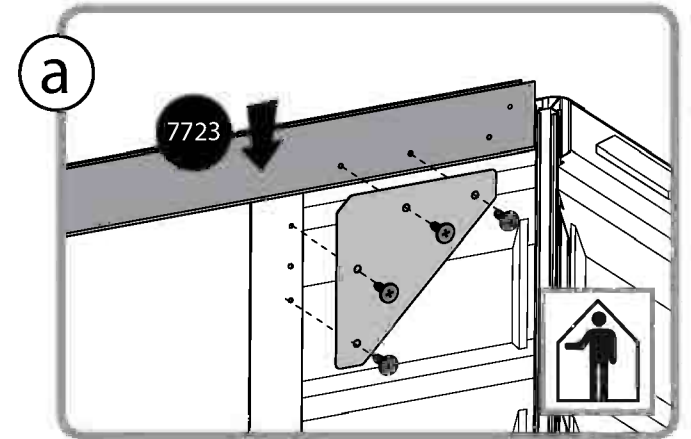
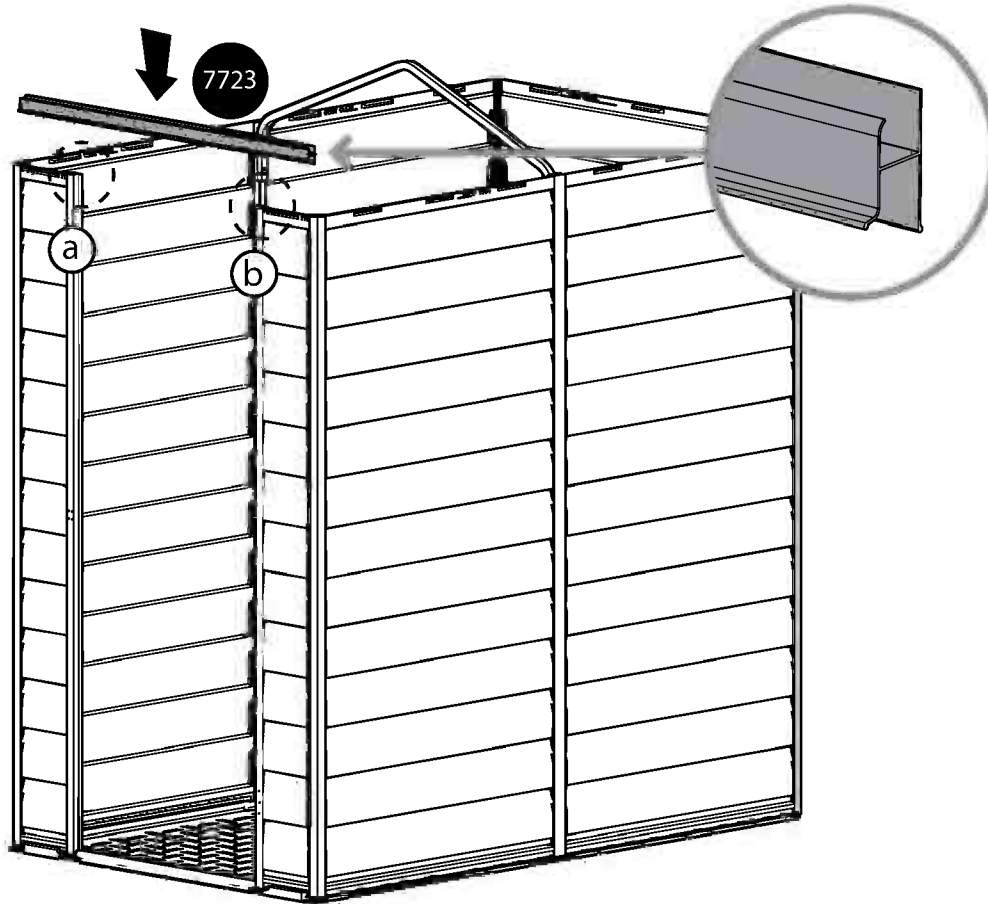
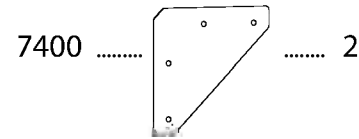
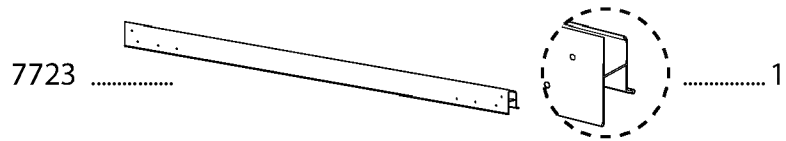
7442 4

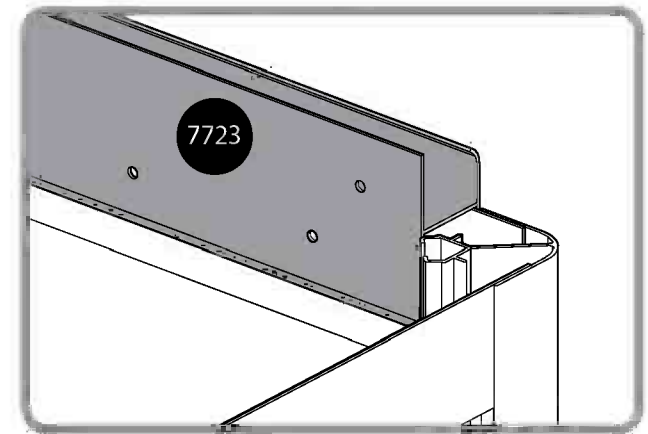
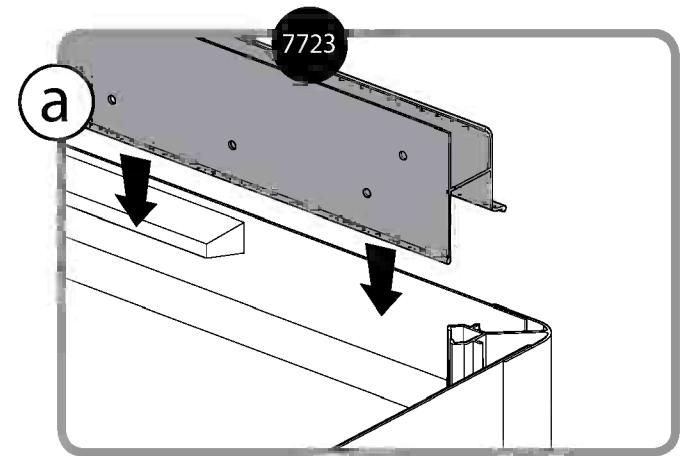
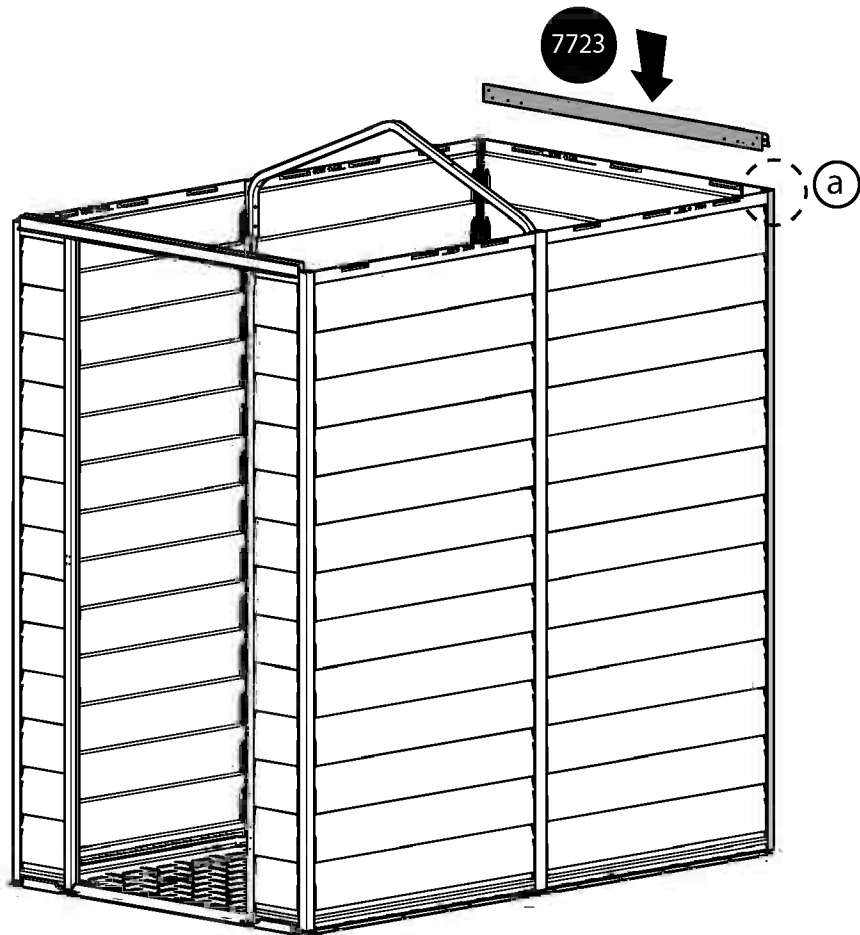
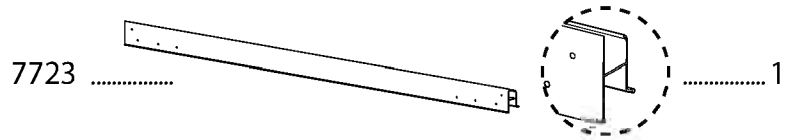





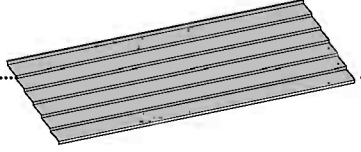
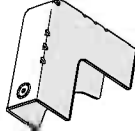



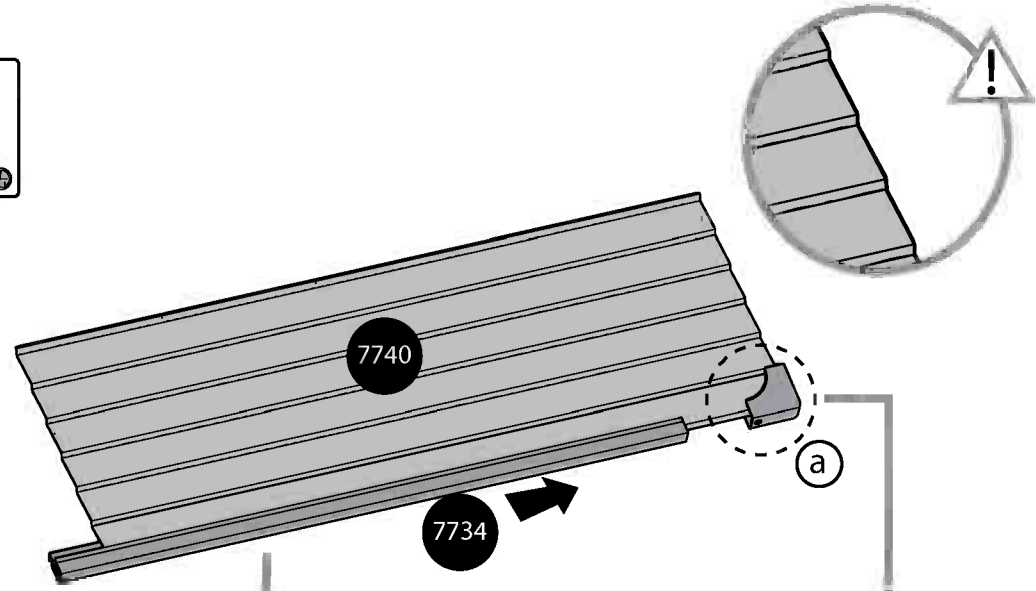
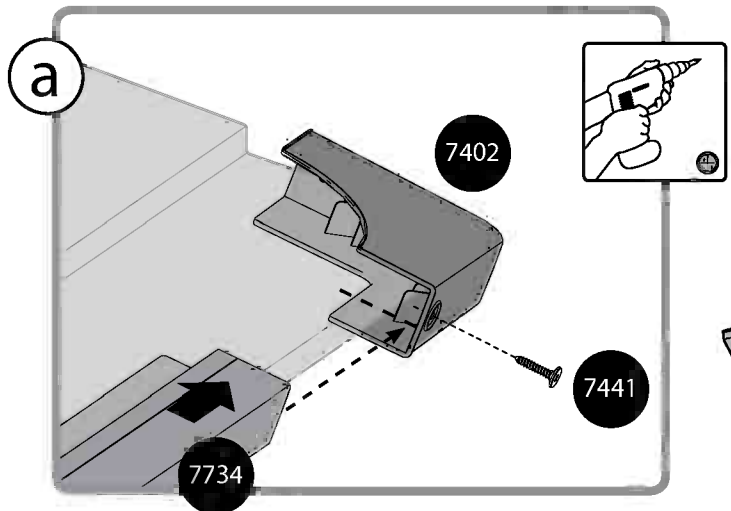

- 7734  2 7740  2 7402  2 7441  2

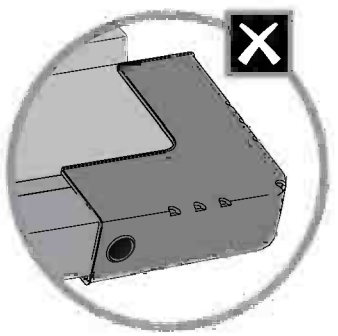
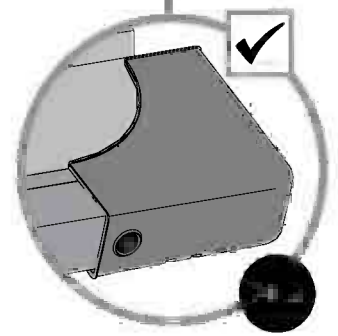
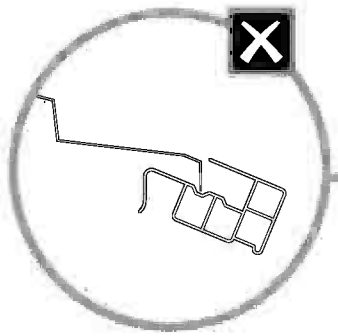
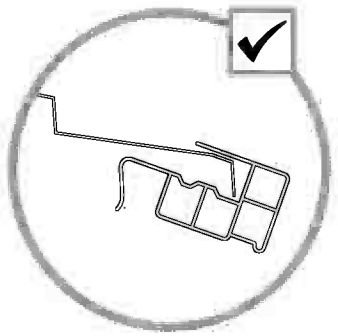

x2



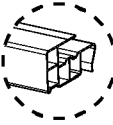

- 7366   2
- 7441  2





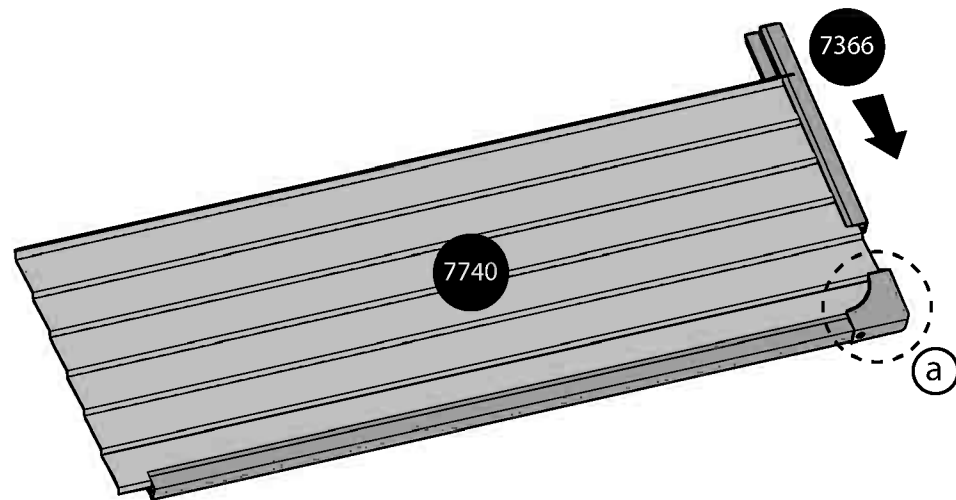
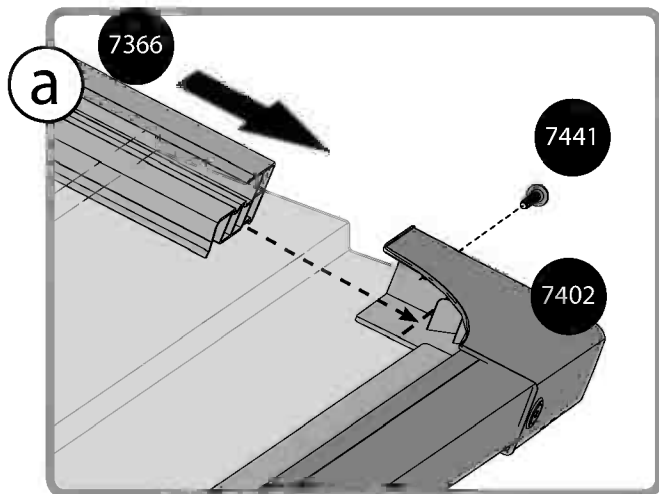

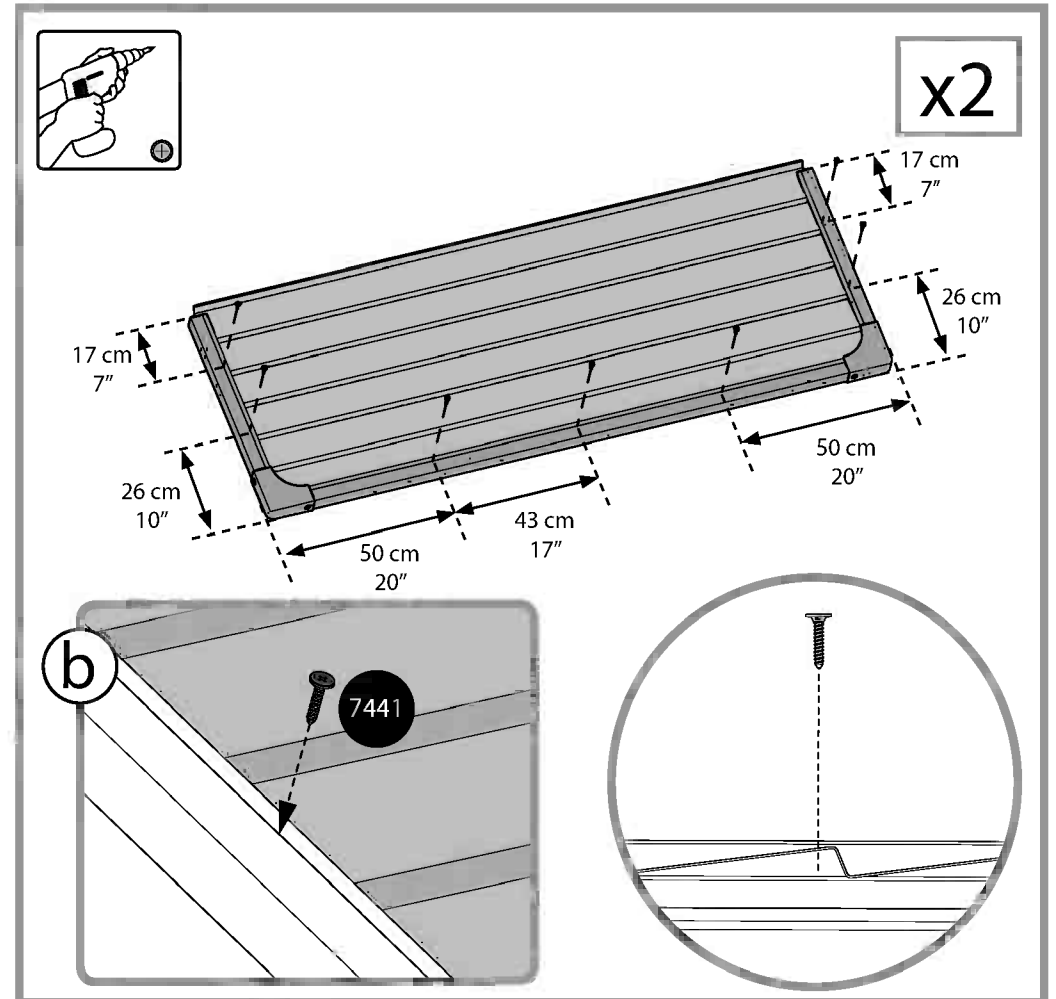
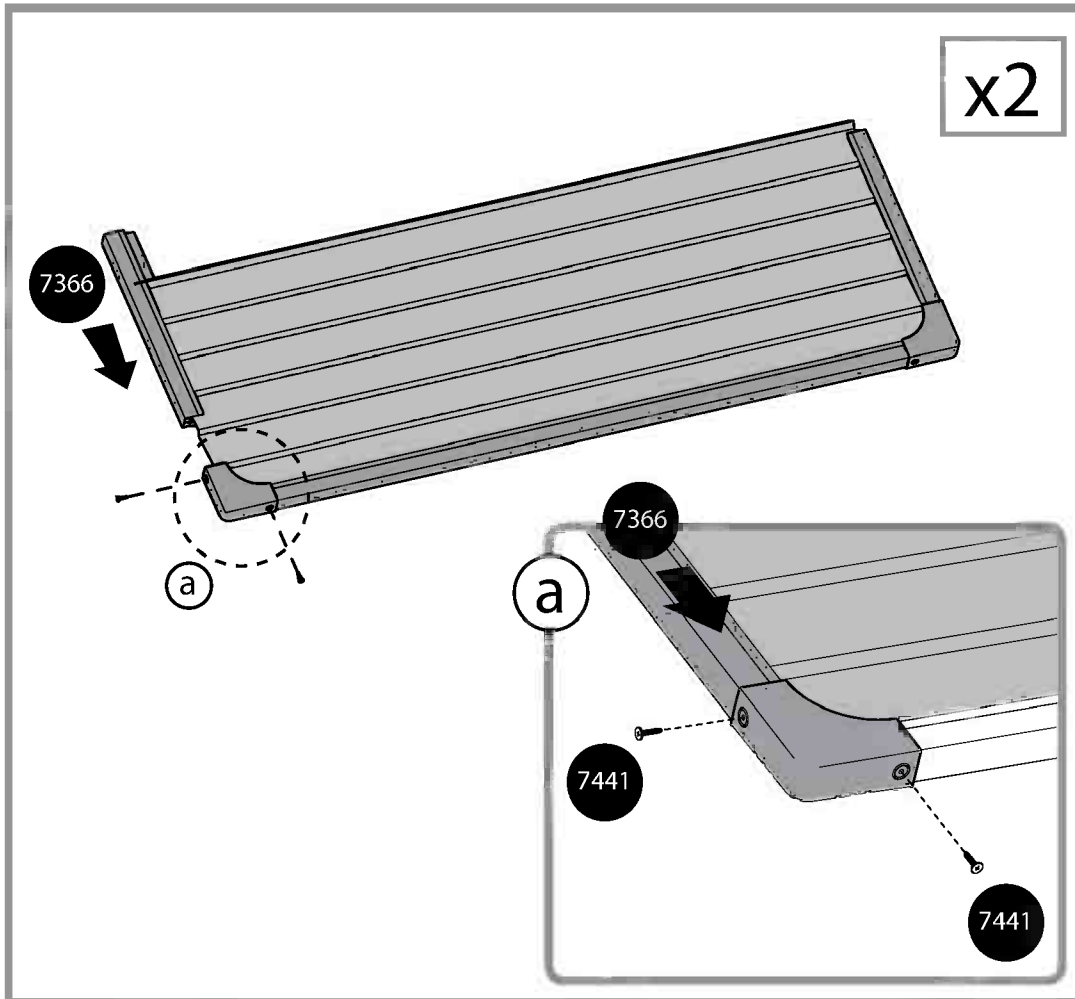
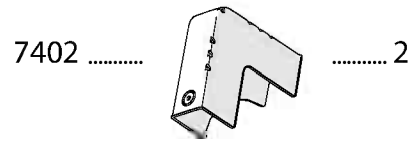
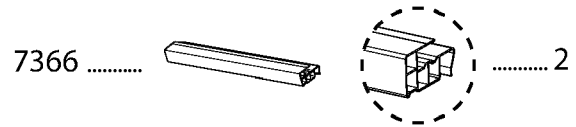
x2





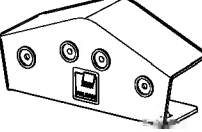

- 7731   1
- 7403  2
- 7445  4

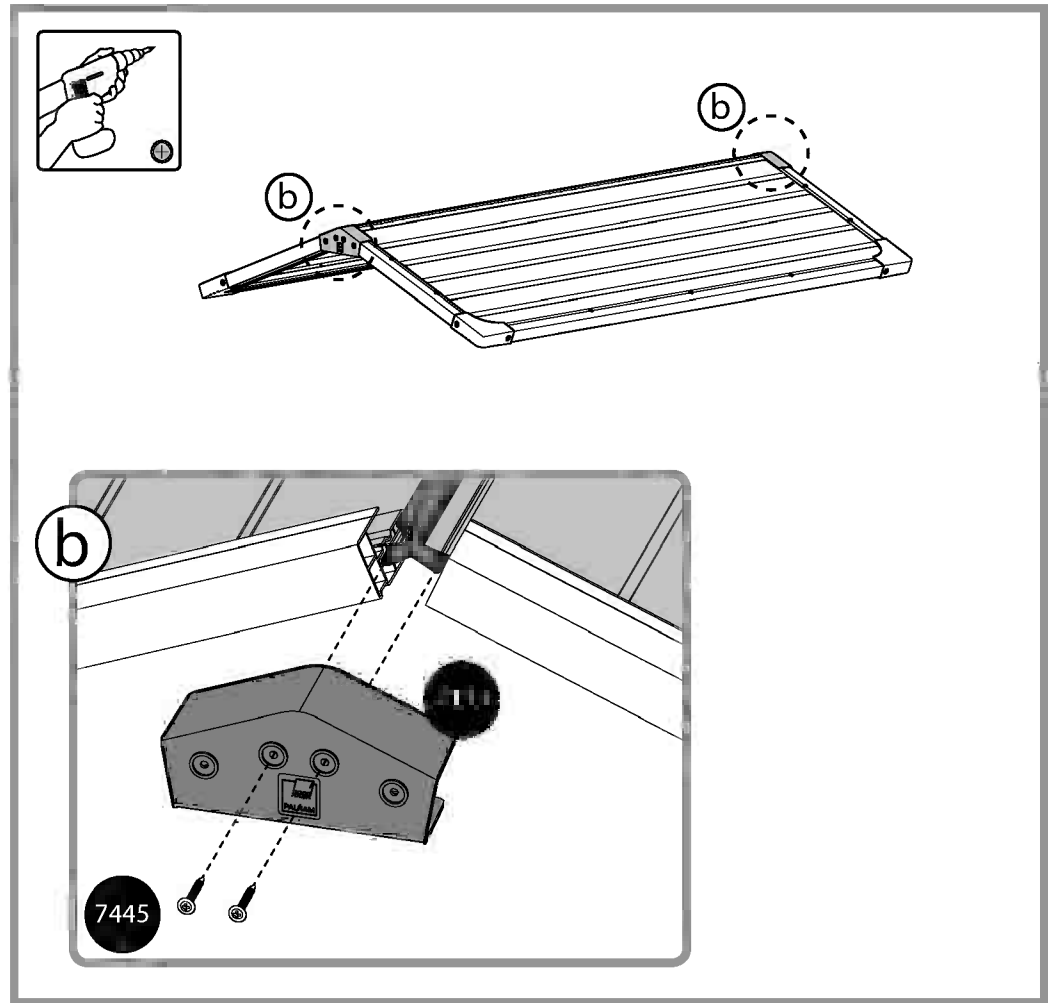
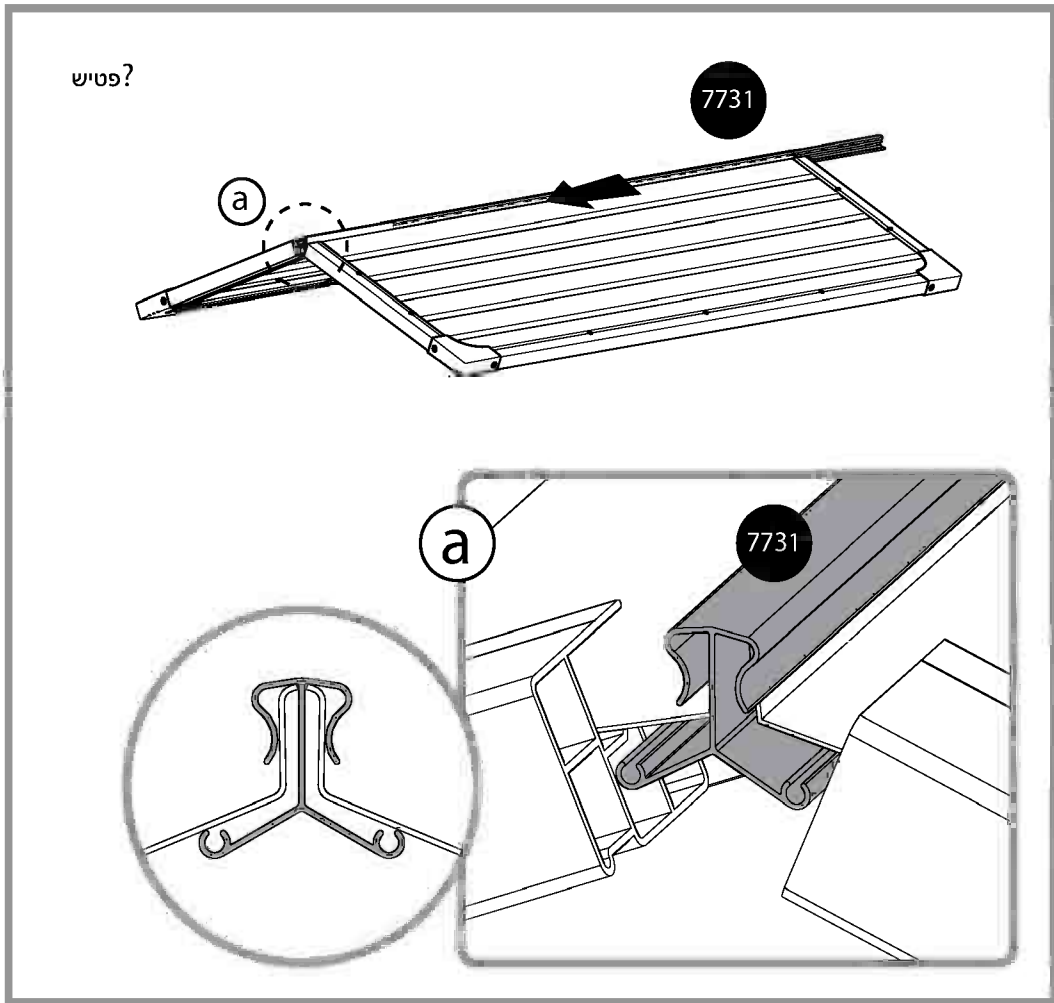

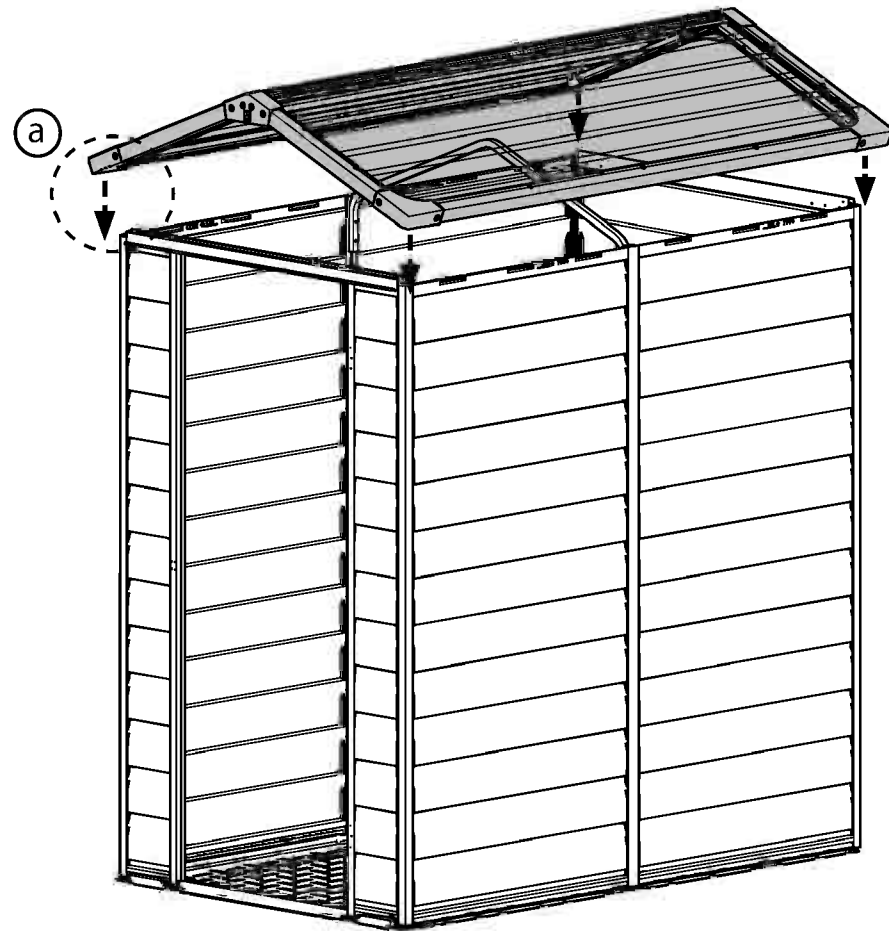
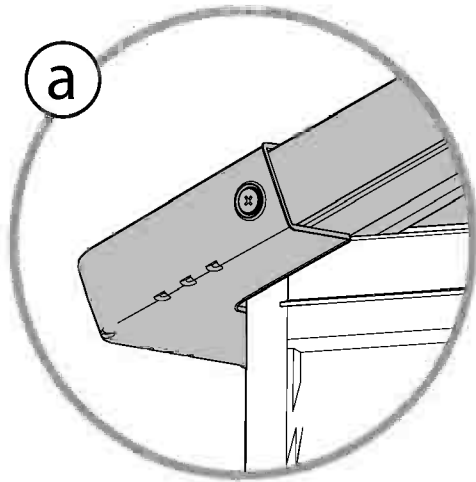



7388



..... 2

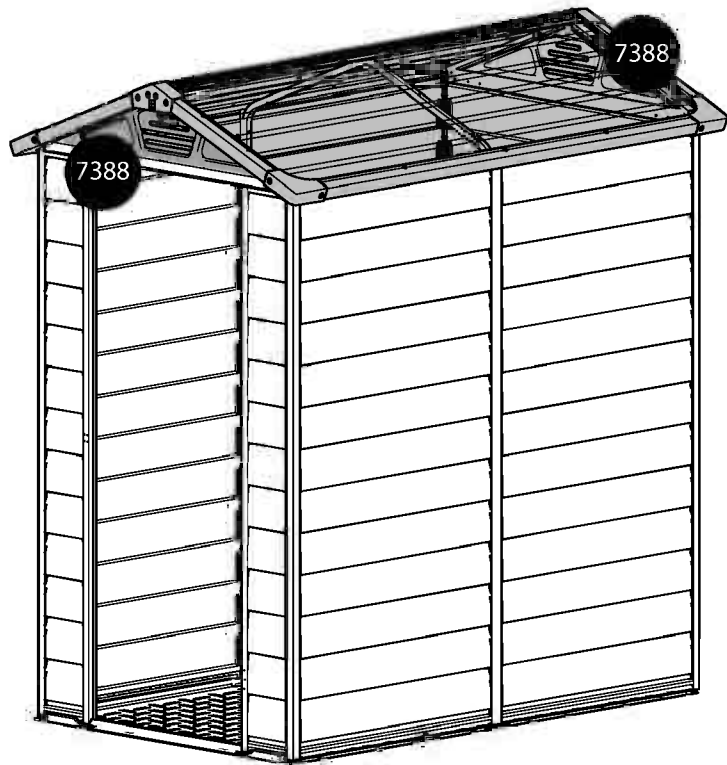

a

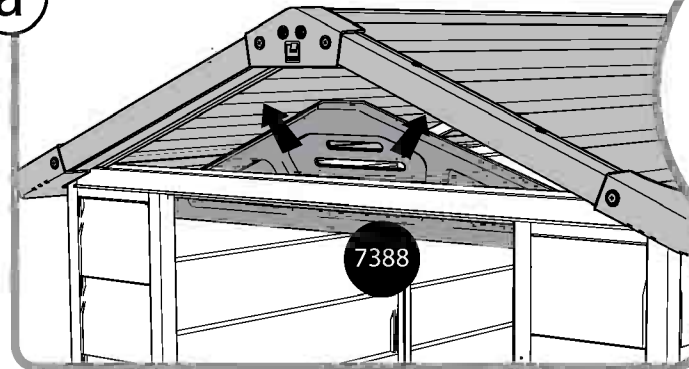

b

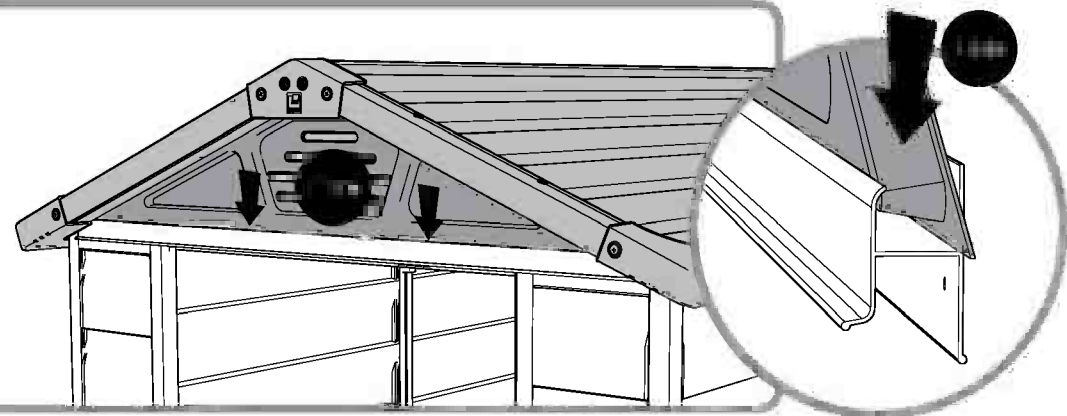

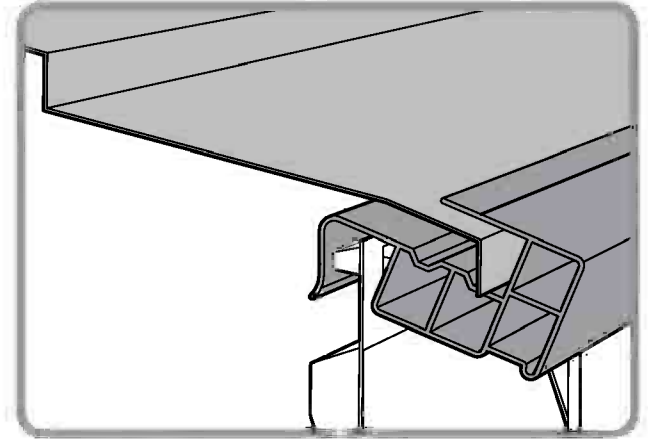
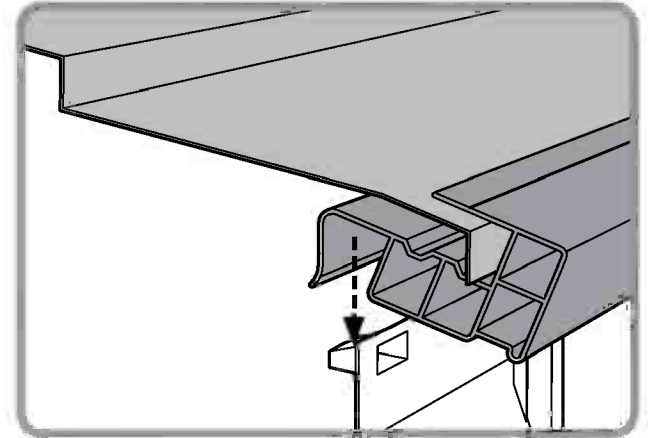
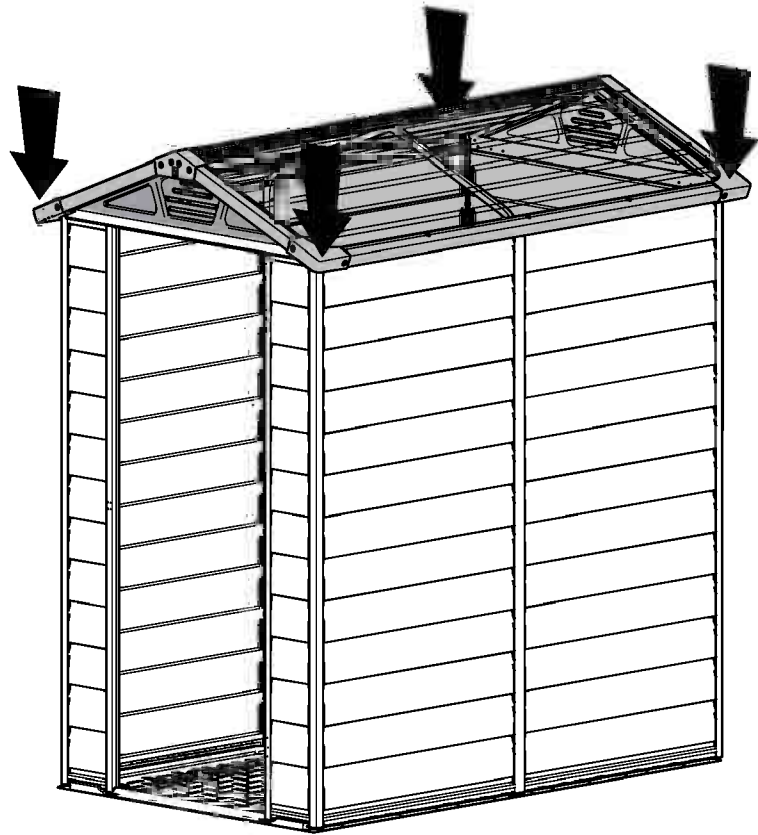
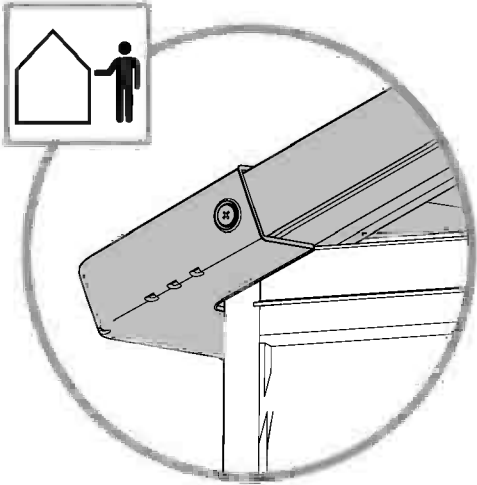
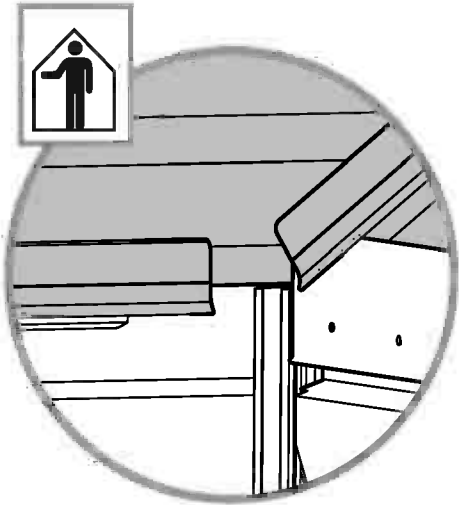



7441  4

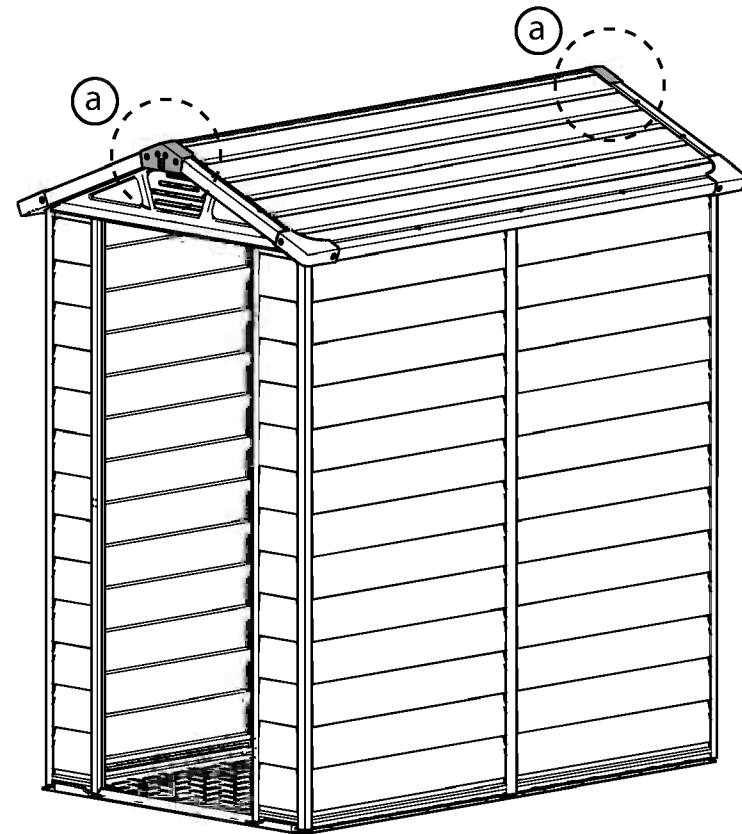
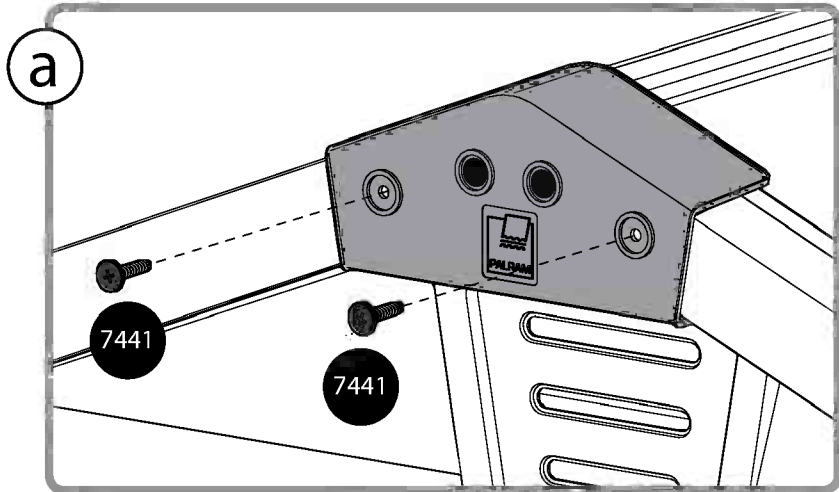
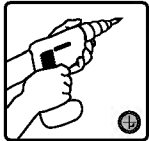

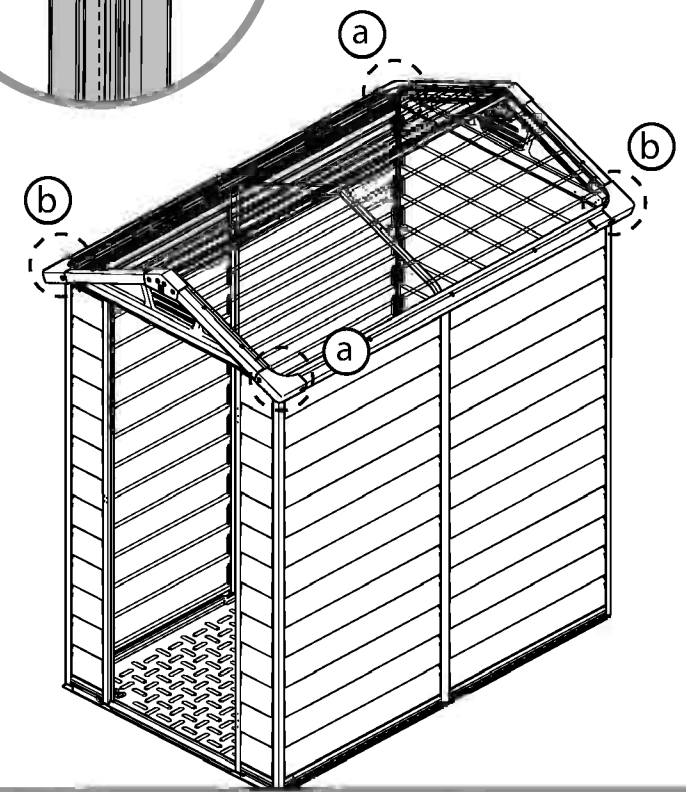
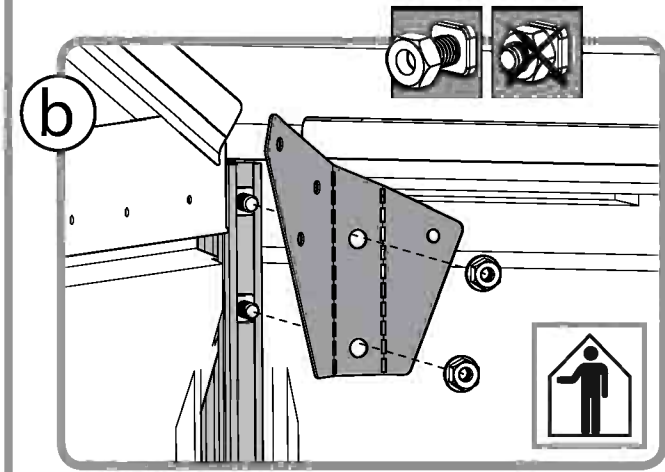
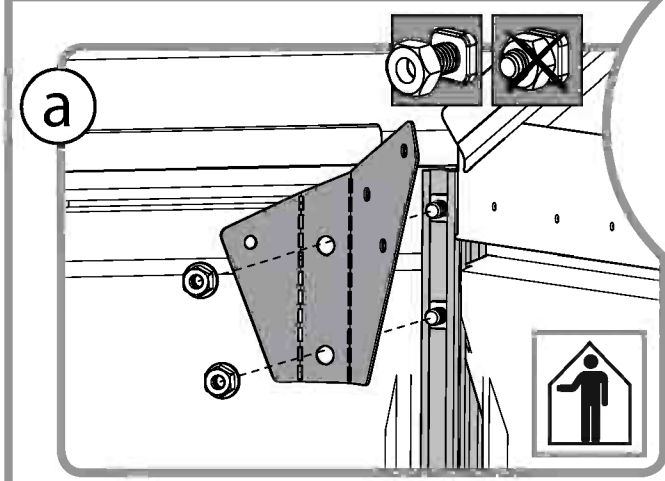
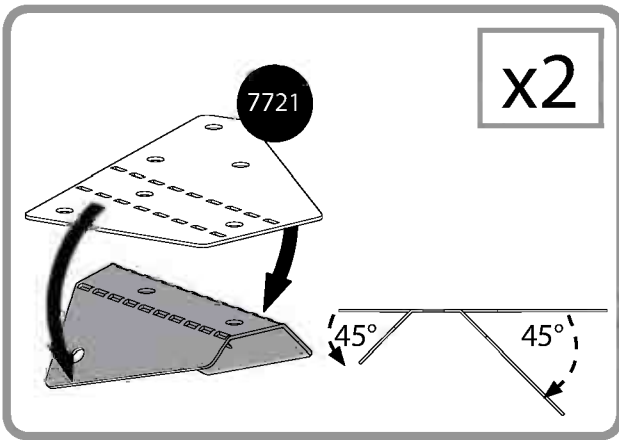
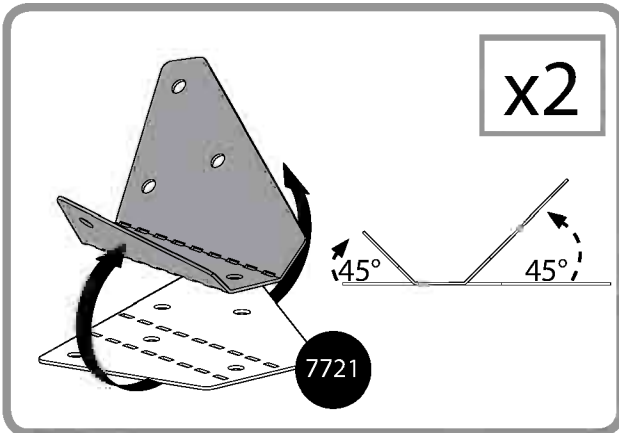
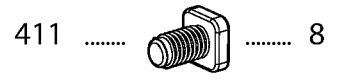
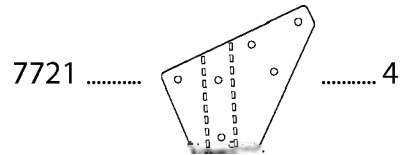
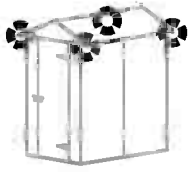

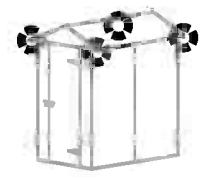

7441  8 7442  8

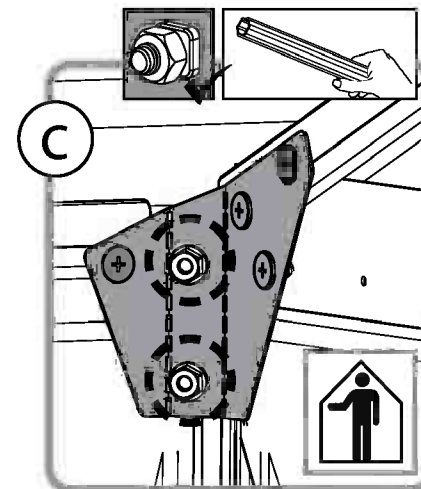
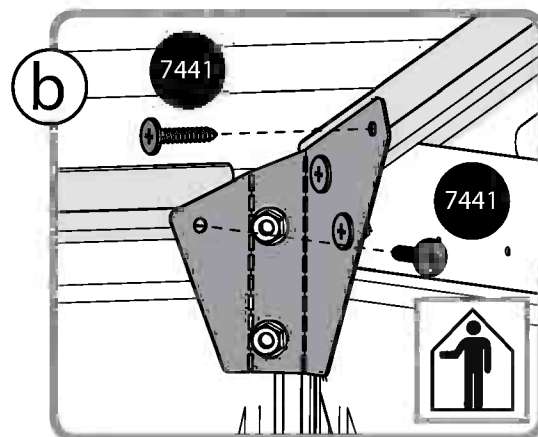
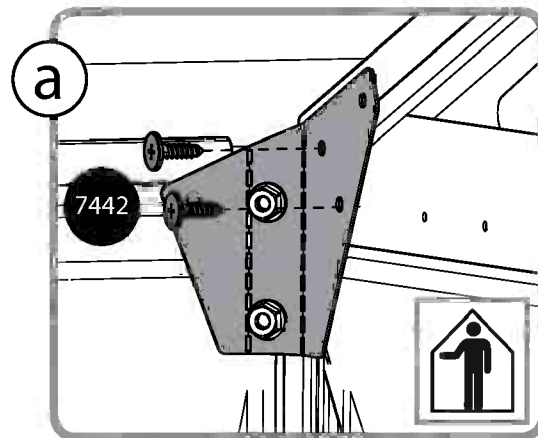
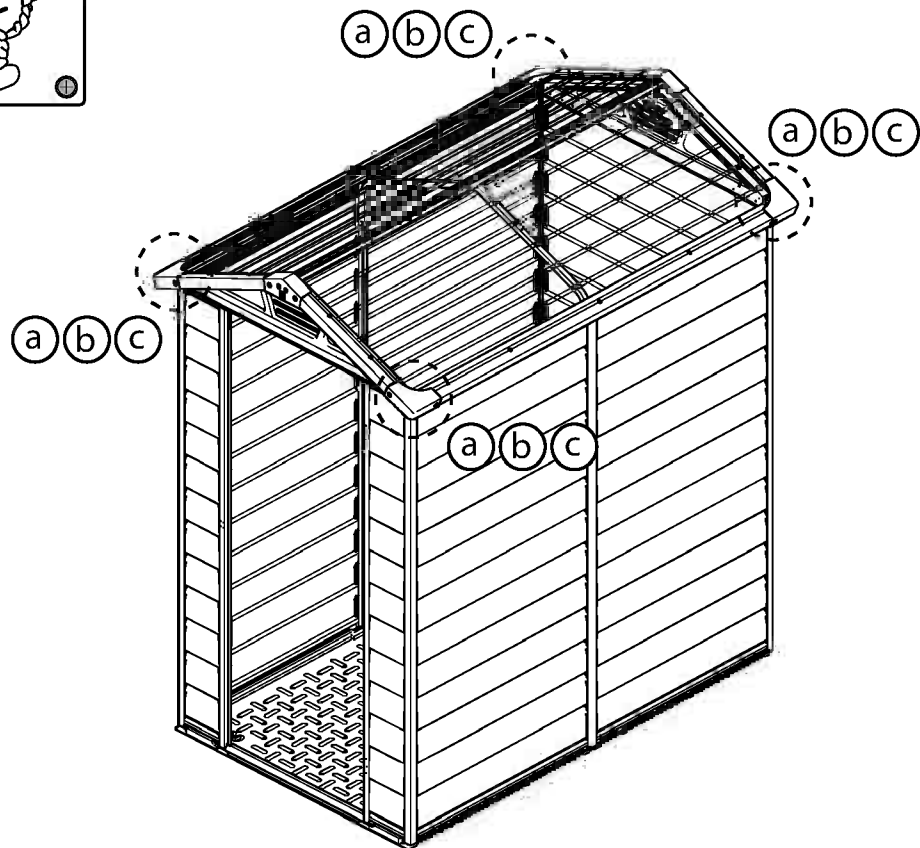
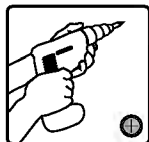



7441
..... 12

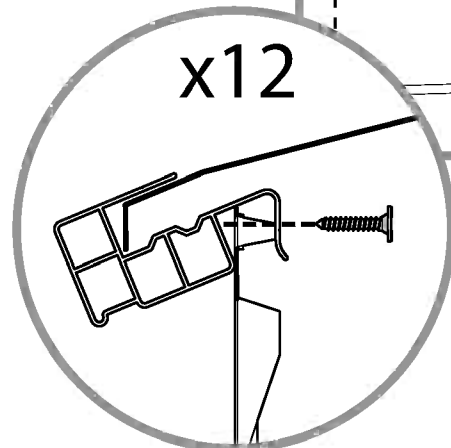
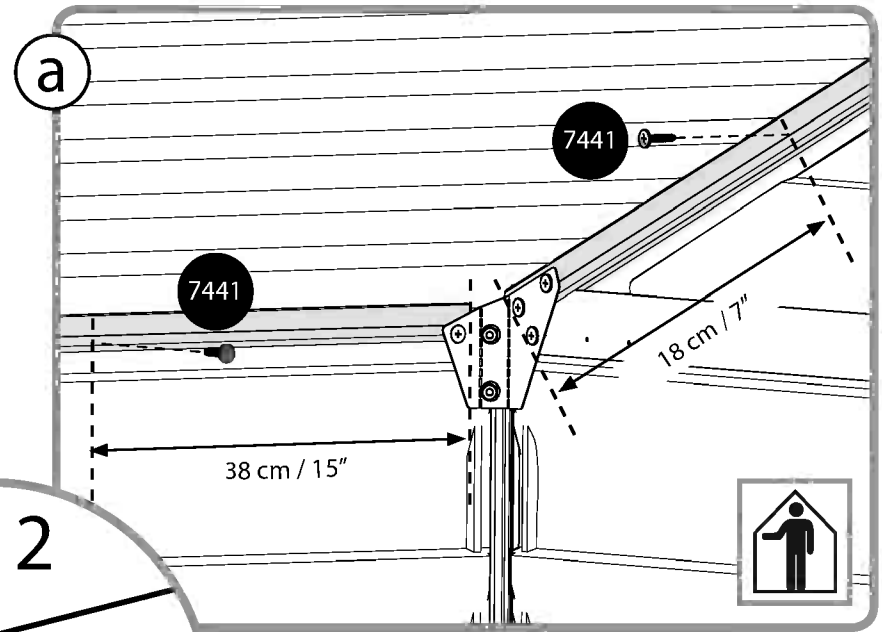
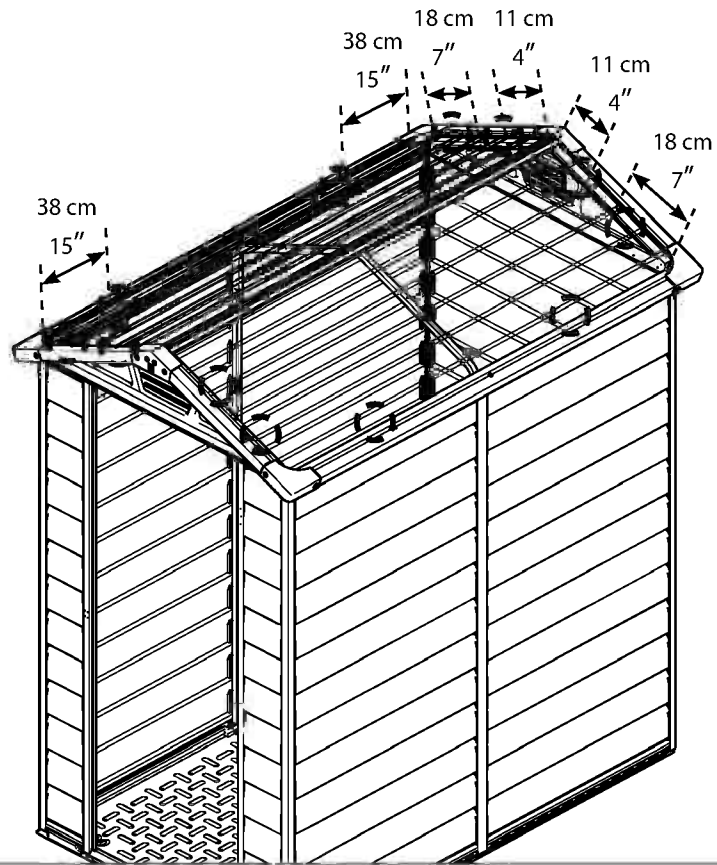
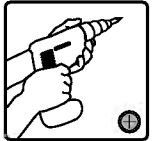

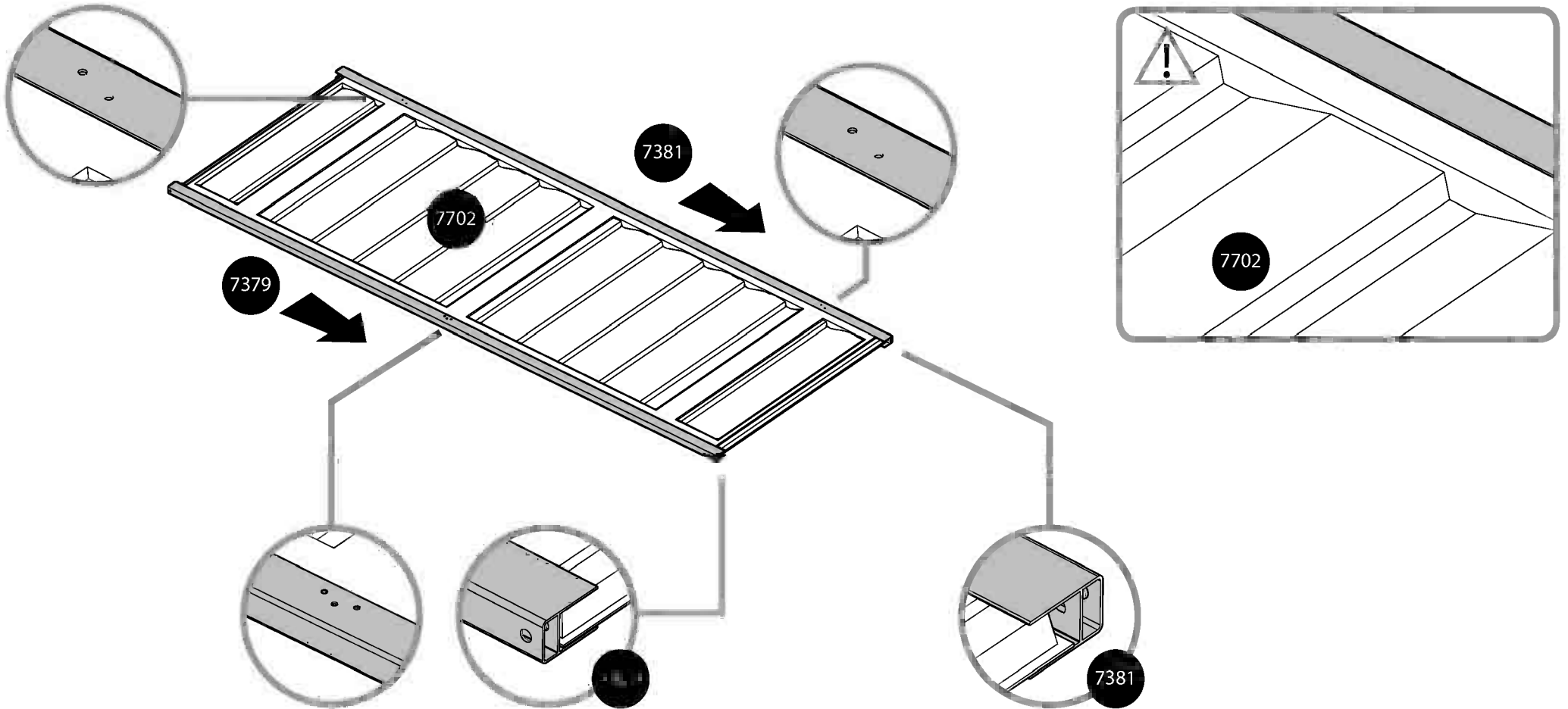
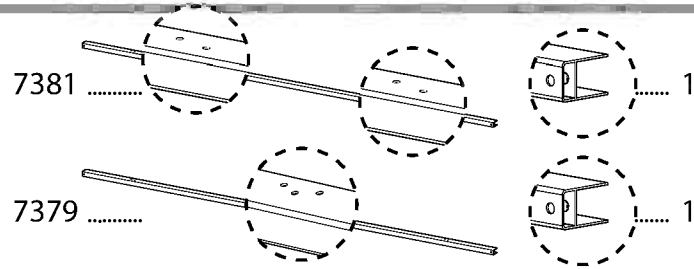
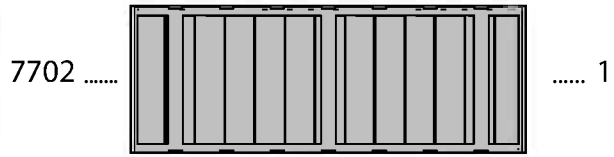

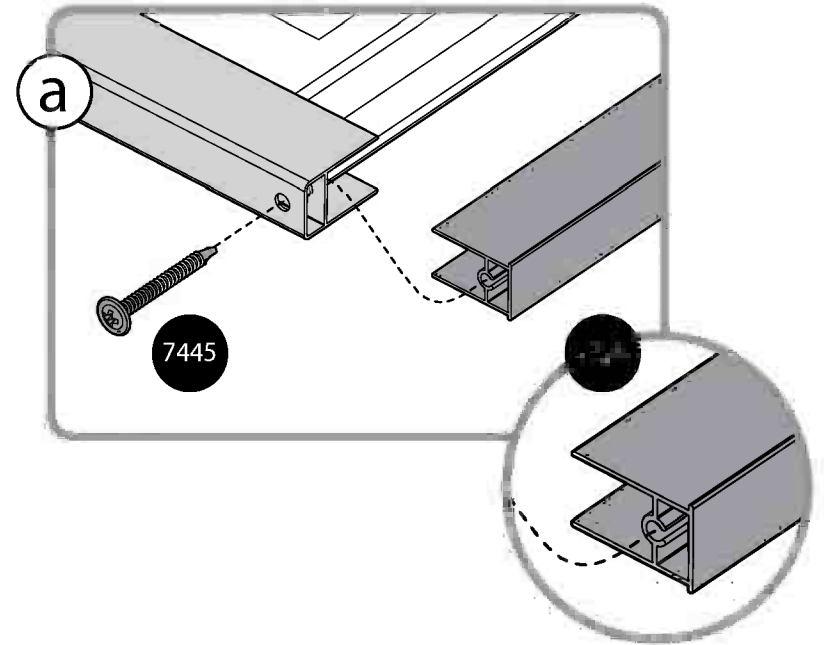
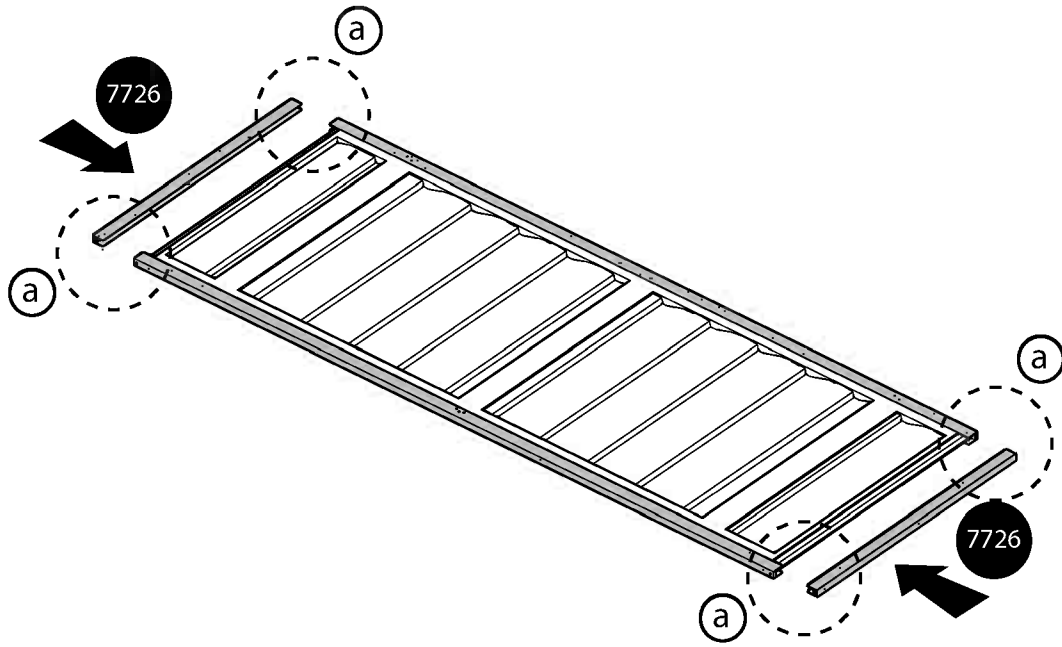



- 7356 2
- 7444 4
- 428 4
- 431 4
- 422 4

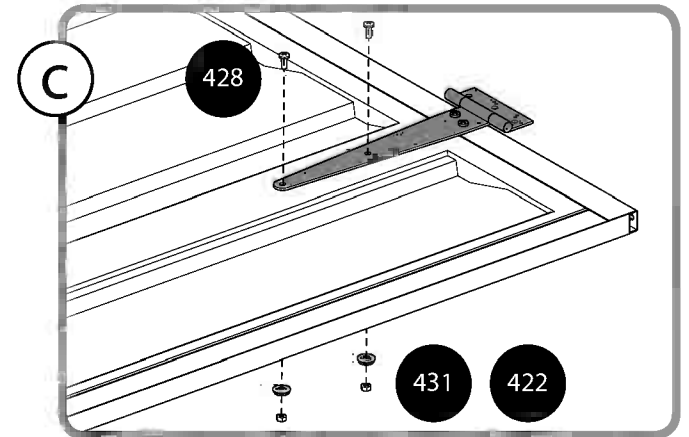
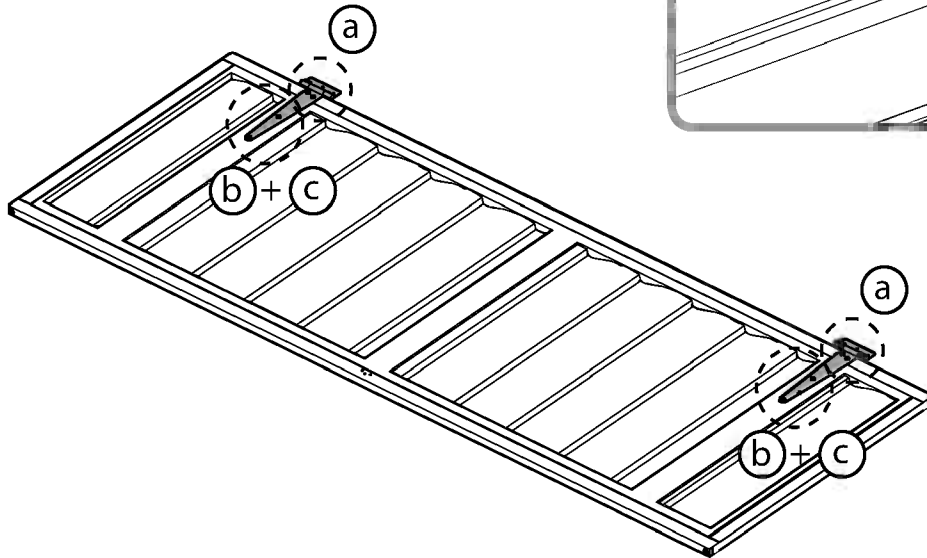
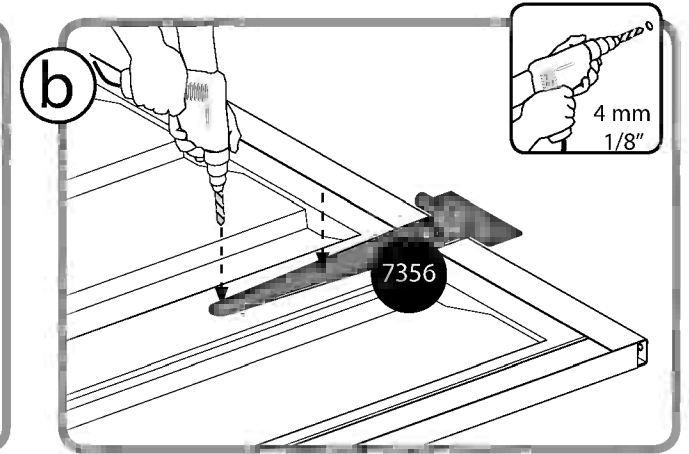
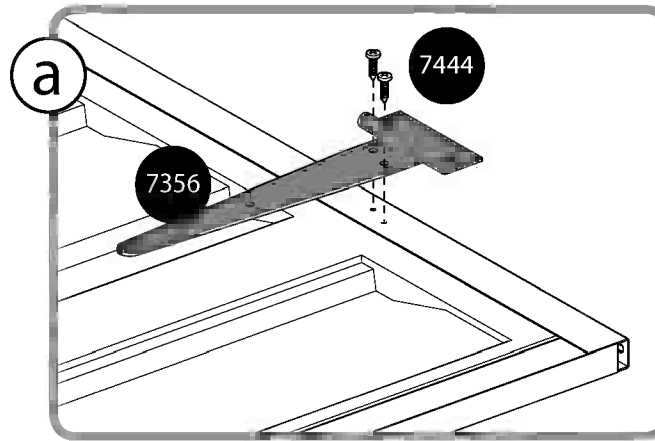
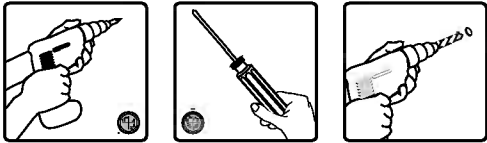



7355 A 1 7444 3

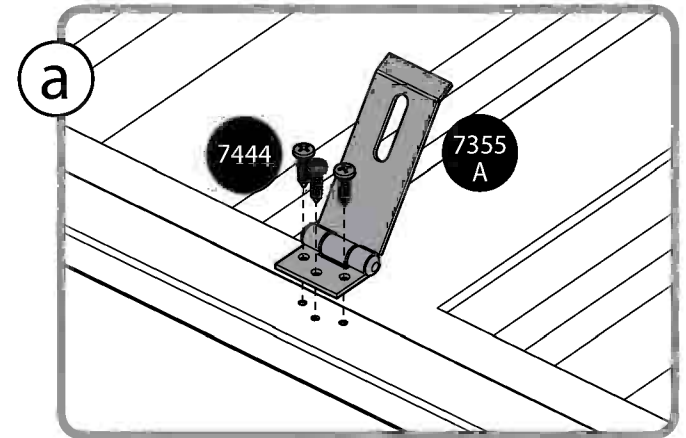
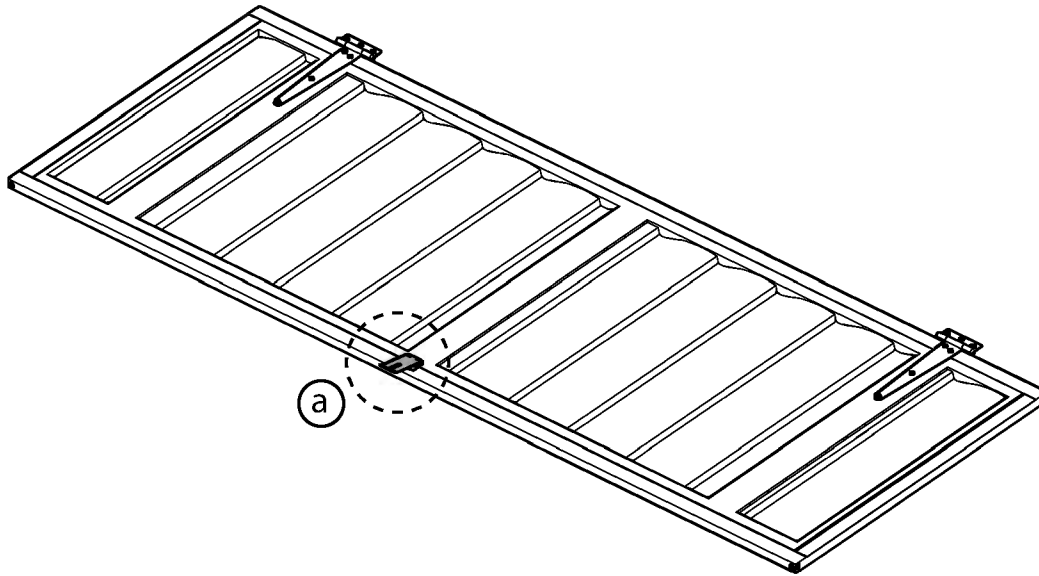
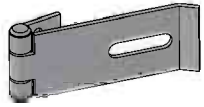



7444  6

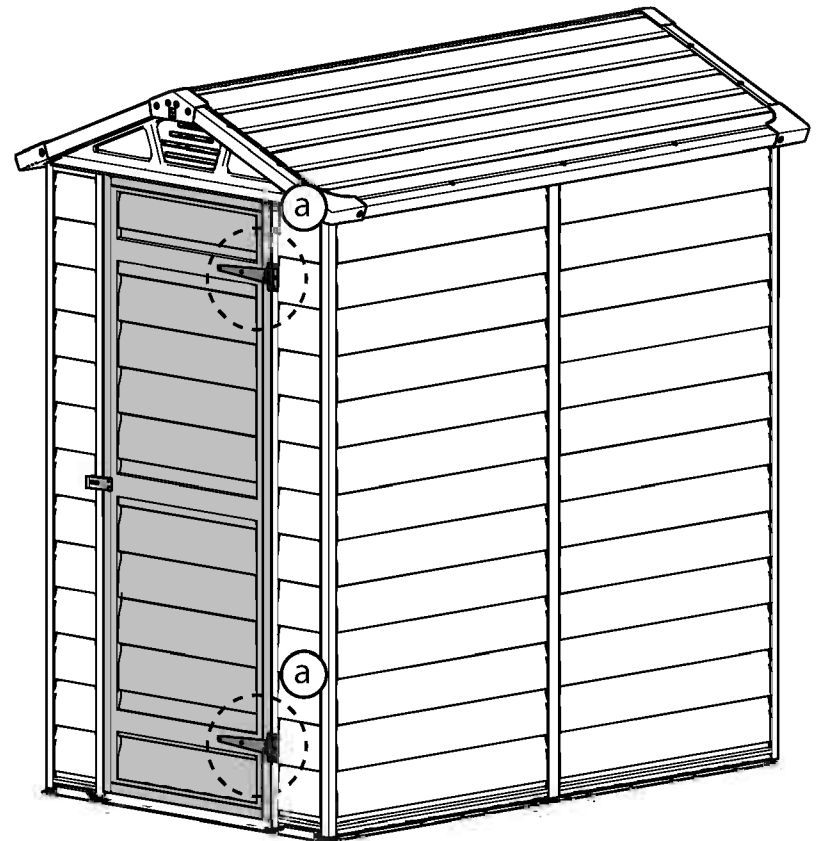
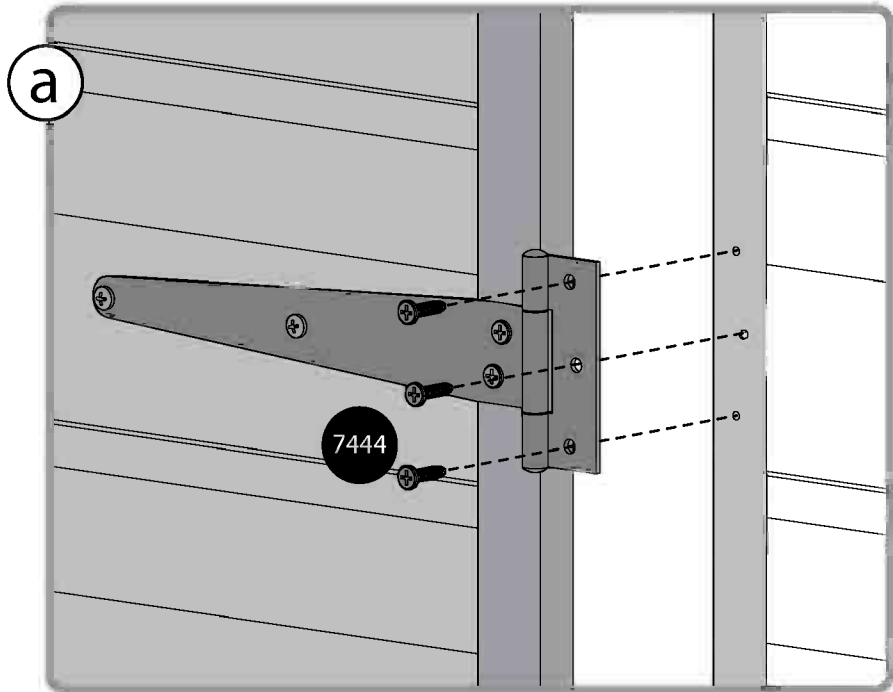
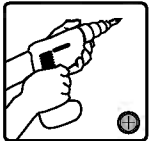



7355 B  4

7444  4

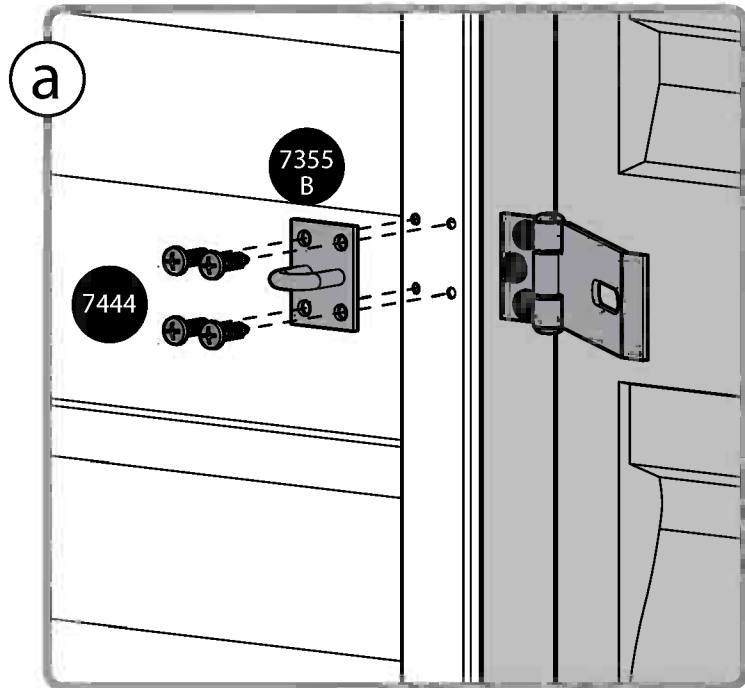
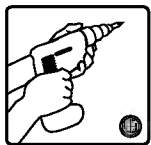

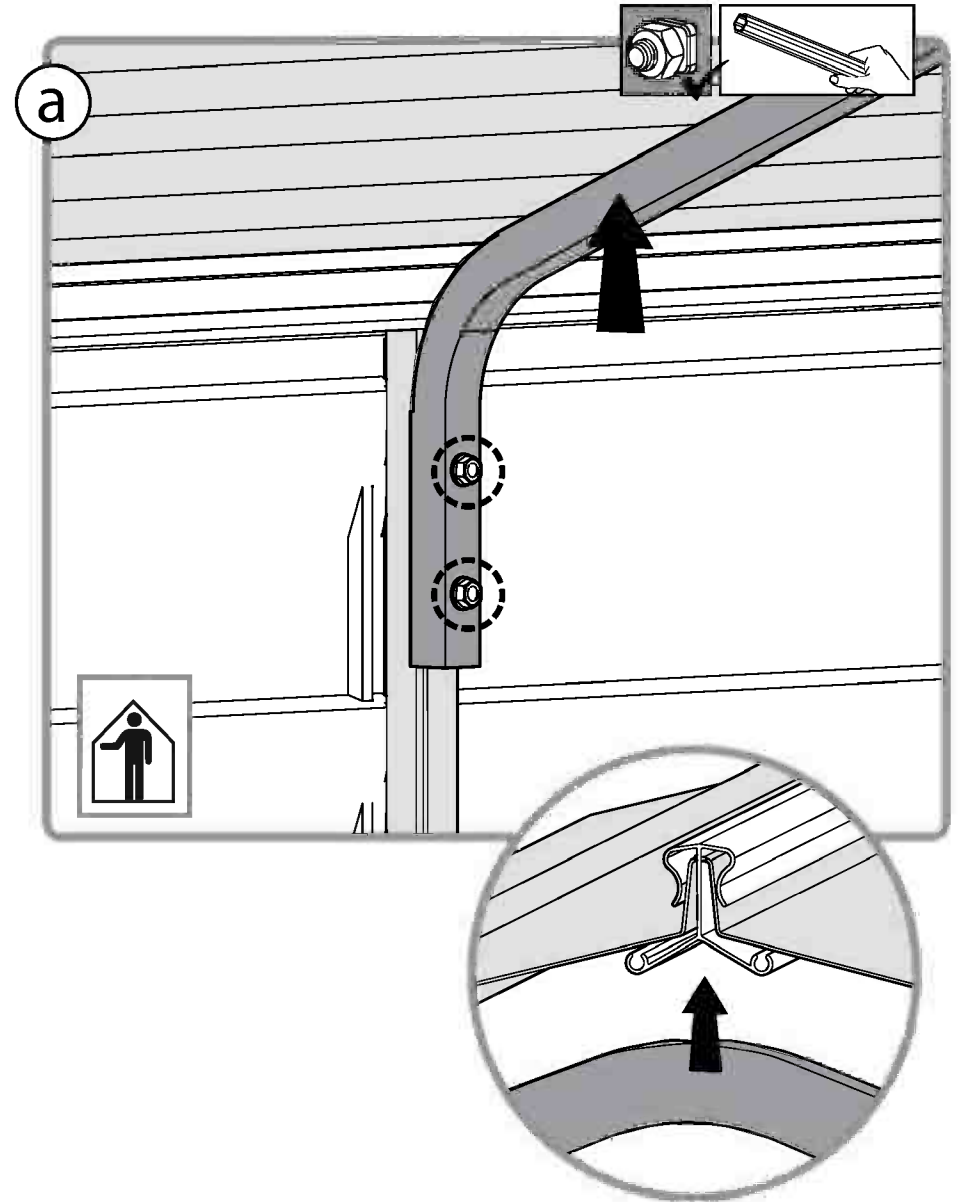
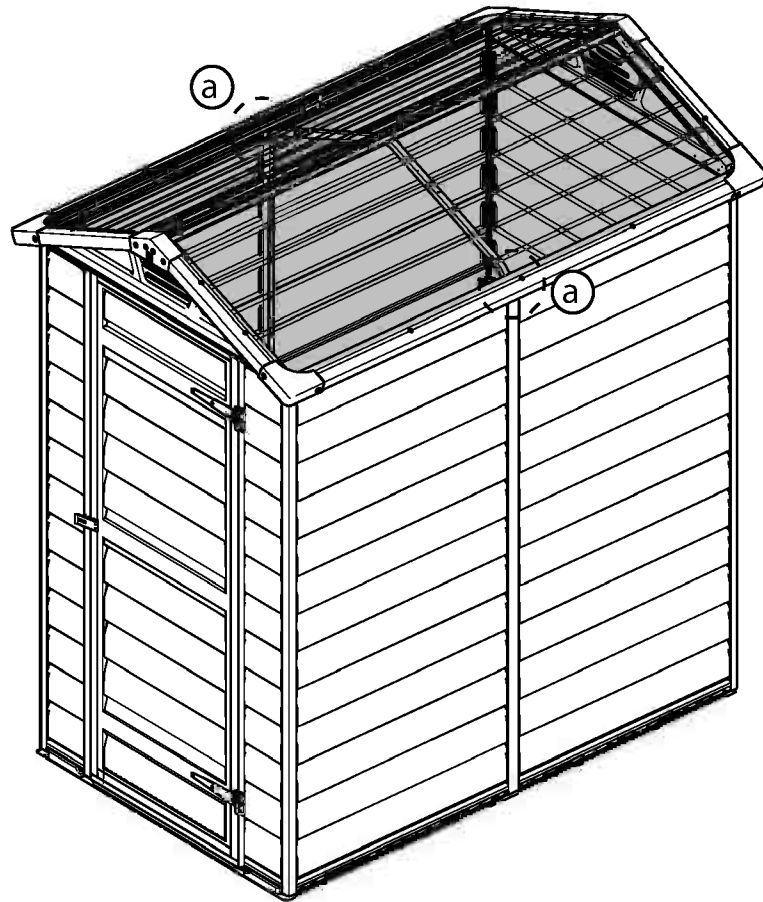



7524  1

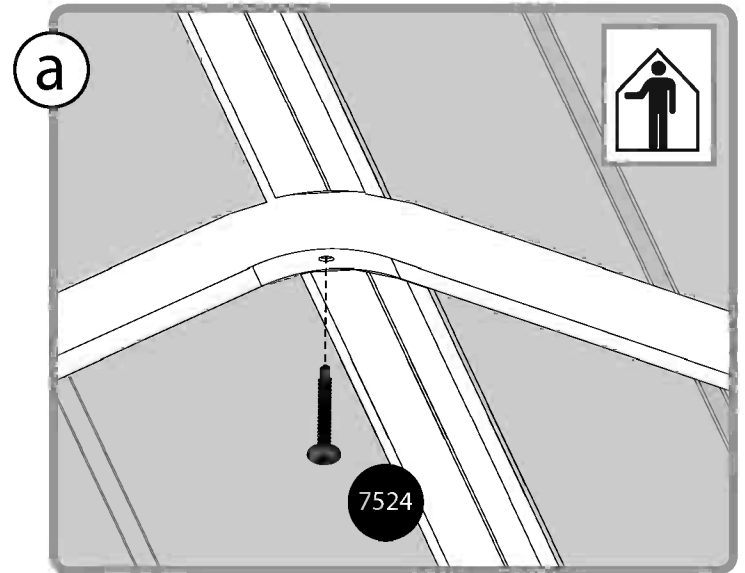
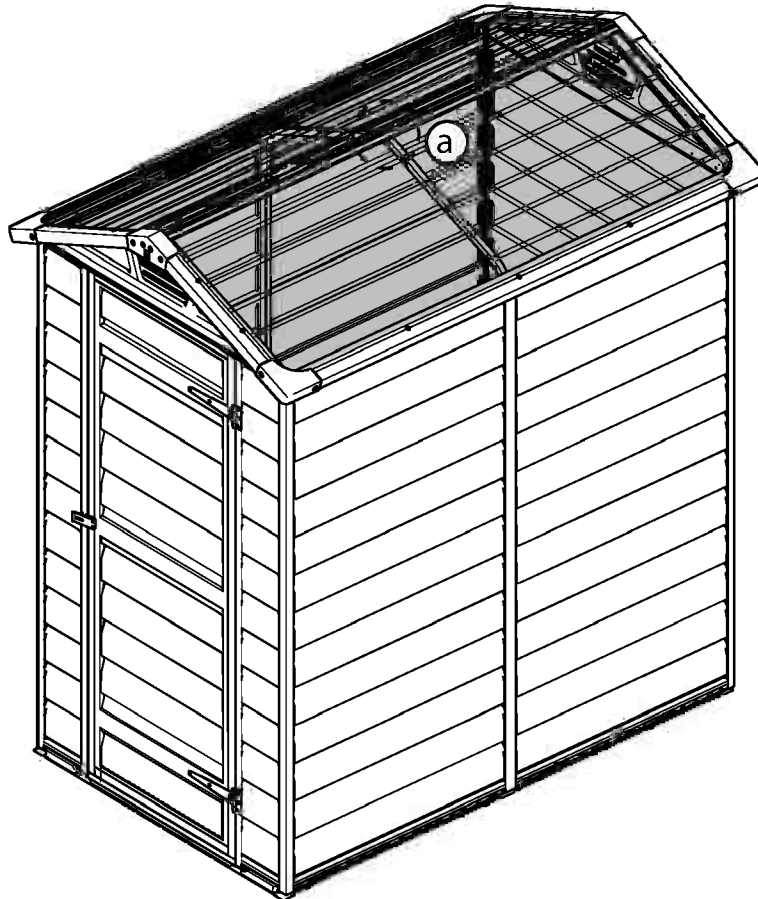
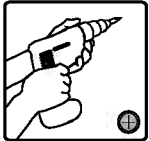



7566 2



4036 2



431 2



422 2

